

MONO HEAT PUMPS

INSTALLATION AND OWNER'S MANUAL

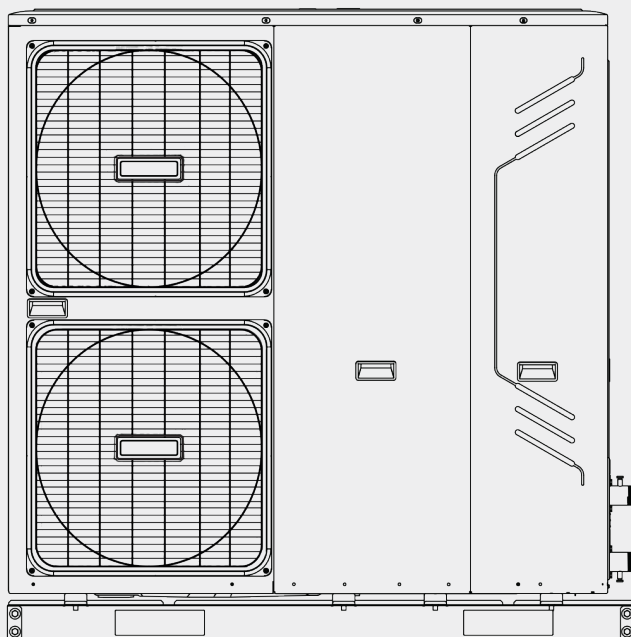

IMPORTANT NOTE:

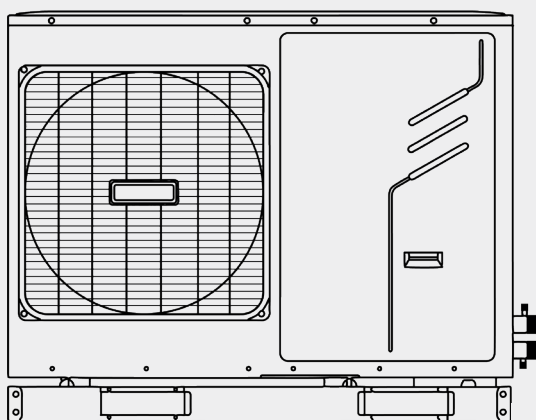

Thank you very much for purchasing our product,
Before using your unit , please read this manual carefully and keep it for future reference.

INVERTER

CONTENTS

1 SAFETY CONSIDERATIONS	02
2 GENERAL INFORMATION	04
3 ACCESSORIES	
• 3.1 Accessories supplied with the unit	06
• 3.2 Accessories available from supplier	06
4 BEFORE INSTALLATION	06
5 IMPORTANT INFORMATION FOR THE REFRIGERANT	07
6 INSTALLATION SITE	
• 6.1 Selecting a location in cold climates	09
• 6.2 Selecting a location in hot climates	09
7 INSTALLATION PRECAUTIONS	
• 7.1 Dimensions	10
• 7.2 Installation requirements	10
• 7.3 Drain hole position	11
• 7.4 Servicing space requirements	11
8 TYPICAL APPLICATIONS	
• 8.1 Application 1	12
• 8.2 Application 2	13
• 8.3 Application 3	15
• 8.4 Application 4	16
• 8.5 Application 5	17
• 8.6 Application 6	20
• 8.7 Application 7	22
• 8.8 Application 8	23
9 OVERVIEW OF THE UNIT	
• 9.1 Disassembling the unit	24
• 9.2 Main components	25
• 9.3 Electronic control box	27
• 9.4 Water piping	34
• 9.5 Adding water	38
• 9.6 Water piping insulation	39
• 9.7 Field wiring	39
10 START-UP AND CONFIGURATION	
• 10.1 Climate related curves	50
• 10.2 DIP switch settings overview	52

• 10.3 Initial start-up at low outdoor ambient temperature	52
• 10.4 Pre-operation checks	52
• 10.5 Powering up the unit	53
• 10.6 Setting the pump speed	53
• 10.7 Field settings	54
11 TEST RUN AND FINAL CHECKS	
• 11.1 Final checks	66
• 11.2 Test run operation (manually)	66
12 MAINTENANCE AND SERVICE	66
13 TROUBLE SHOOTING	
• 13.1 General guidelines	67
• 13.2 General symptoms	68
• 13.3 Operation parameter	70
• 13.4 Error codes	71
14 TECHNICAL SPECIFICATIONS	
• 14.1 General	77
• 14.2 Electrical specifications	77
15 REPLACEMENT OF SAFETY VALVE	78
16 INFORMATION SERVICING	78

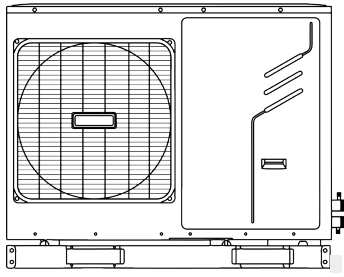

5/7/9 kW

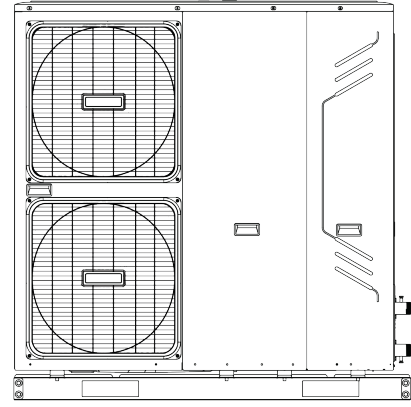

12/14/16 kW

Wiring diagram: 12~16kW(3-phase) for example

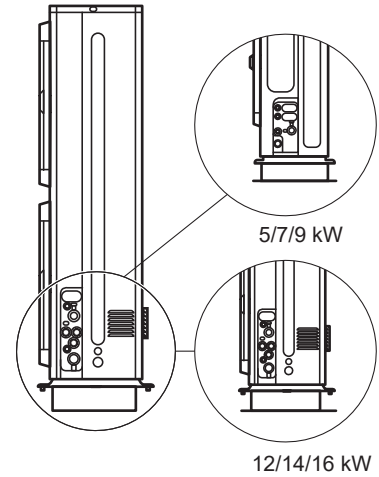
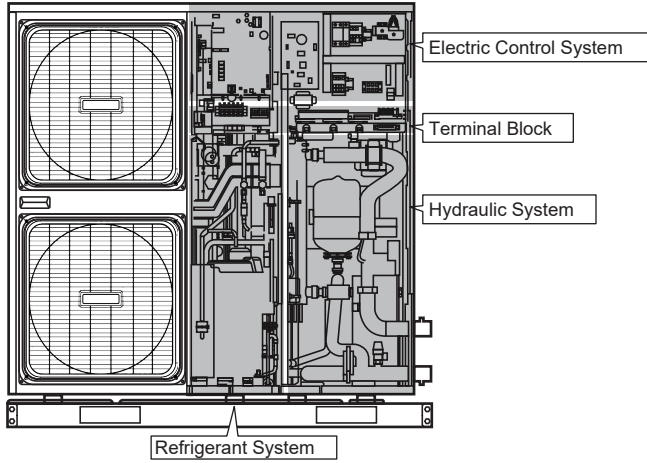

Please remove the hollow plate after installation.

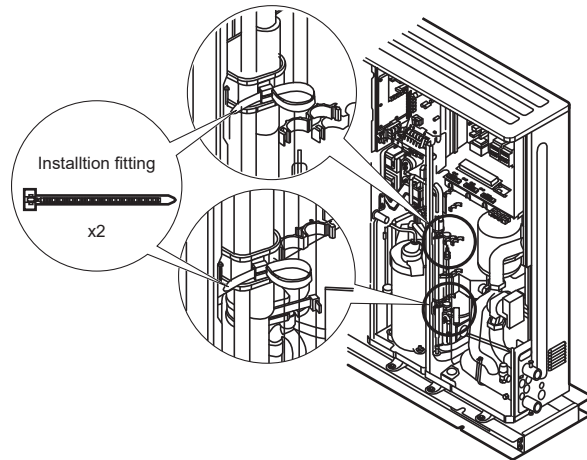
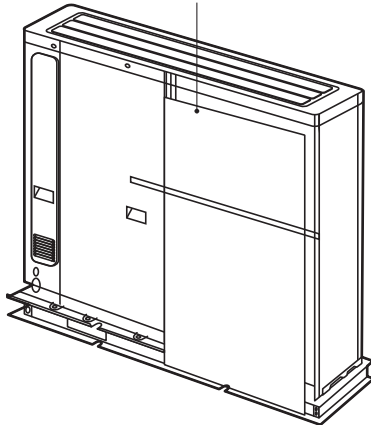

NOTE

The picture and function described in this manual contain the backup heater components.

Unit	1-phase						3-phase		
	5	7	9	12	14	16	12	14	16
Capacity of backup heater	3kW			3kW or 4.5kW			4.5kW		
	Backup heater(optional)								

The standard unit is without backup heater. Backup heater kit is an optional part for 5,7,9kW models. Backup heater can be integrated in the unit for customized models(12,14,16kW).
 If the backup heater is installed, the port (CN6) for T1 in the main control board of hydraulic compartment should connect to the corresponding port in the backup heater kit (more details please refer to 9.2.2 Hydraulic system diagram).

1 SAFETY PRECAUTIONS

The precautions listed here are divided into the following types. They are quite important, so be sure to follow them carefully. Meanings of DANGER, WARNING, CAUTION and NOTE symbols.

INFORMATION

- Read these instructions carefully before installation. Keep this manual in a handy for future reference.
- Improper installation of equipment or accessories may result in electric shock, short-circuit, leakage, fire or other damage to the equipment. Be sure to only use accessories made by the supplier, which are specifically designed for the equipment and make sure to get installation done by a professional.
- All the activities described in this manual must be carried out by a licensed technician. Be sure to wear adequate personal protection equipment such as gloves and safety glasses while installing the unit or carrying out maintenance activities.
- Contact your dealer for any further assistance.



Caution: Risk of fire/
flammable materials

WARNING

Servicing shall only be performed as recommended by the equipment manufacturer. Maintenance and repair requiring the assistance of other skilled personnel shall be carried out under the supervision of the person competent in the use of flammable refrigerants.

DANGER

Indicates an imminently hazardous situation which if not avoided, will result in death or serious injury.

WARNING

Indicates a potentially hazardous situation which if not avoided, could result in death or serious injury.





CAUTION

Indicates a potentially hazardous situation which if not avoided, may result in minor or moderate injury. It is also used to alert against unsafe practices.

NOTE

Indicates situations that could only result in accidental equipment or property damage.

Explanation of symbols displayed on the indoor unit or outdoor unit

	WARNING	This symbol shows that this appliance used a flammable refrigerant. If the refrigerant is leaked and exposed to an external ignition source, there is a risk of fire.
	CAUTION	This symbol shows that the operation manual should be read carefully.
	CAUTION	This symbol shows that a service personnel should be handling this equipment with reference to the installation manual.
	CAUTION	This symbol shows that a service personnel should be handling this equipment with reference to the installation manual.
	CAUTION	This symbol shows that information is available such as the operating manual or installation manual.

DANGER

- Before touching electric terminal parts, turn off power switch.
- When service panels are removed, live parts can be easily touched by accident.
- Never leave the unit unattended during installation or servicing when the service panel is removed.
- Do not touch water pipes during and immediately after operation as the pipes may be hot and could burn your hands. To avoid injury, give the piping time to return to normal temperature or be sure to wear protective gloves.
- Do not touch any switch with wet fingers. Touching a switch with wet fingers can cause electrical shock.
- Before touching electrical parts, turn off all applicable power to the unit.

WARNING

- Tear apart and throw away plastic packaging bags so that children will not play with them. Children playing with plastic bags face danger of death by suffocation.
- Safely dispose of packing materials such as nails and other metal or wood parts that could cause injuries.
- Ask your dealer or qualified personnel to perform installation work in accordance with this manual. Do not install the unit yourself. Improper installation could result in water leakage, electric shocks or fire
- Be sure to use only specified accessories and parts for installation work. Failure to use specified parts may result in water leakage, electric shocks, fire, or the unit falling from its mount.
- Install the unit on a foundation that can withstand its weight. Insufficient physical strength may cause the equipment to fall and possible injury.
- Perform specified installation work with full consideration of strong wind, hurricanes, or earthquakes. Improper installation work may result in accidents due to equipment falling.
- Make certain that all electrical work is carried out by qualified personnel according to the local laws and regulations and this manual using a separate circuit. Insufficient capacity of the power supply circuit or improper electrical construction may lead to electric shocks or fire.
- Be sure to install a ground fault circuit interrupter according to local laws and regulations. Failure to install a ground fault circuit interrupter may cause electric shocks and fire.
- Make sure all wiring is secure. Use the specified wires and ensure that terminal connections or wires are protected from water and other adverse external forces. Incomplete connection or affixing may cause a fire.
- When wiring the power supply, form the wires so that the front panel can be securely fastened. If the front panel is not in place there could be overheating of the terminals, electric shocks or fire.
- After completing the installation work, check to make sure that there is no refrigerant leakage.
- Never directly touch any leaking refrigerant as it could cause severe frostbite. Do not touch the refrigerant pipes during and immediately after operation as the refrigerant pipes may be hot or cold, depending on the condition of the refrigerant flowing through the refrigerant piping, compressor and other refrigerant cycle parts. Burns or frostbite are possible if you touch the refrigerant pipes. To avoid injury, give the pipes time to return to normal temperature or, if you must touch them be sure to wear protective gloves.
- Do not touch the internal parts (pump, backup heater, etc.) during and immediately after operation. Touching the internal parts can cause burns. To avoid injury, give the internal parts time to return to normal temperature or, if you must touch them, be sure to wear protective gloves.

CAUTION

- Ground the unit.
- Grounding resistance should be according to local laws and regulations.
- Do not connect the ground wire to gas or water pipes, lightning conductors or telephone ground wires.
- Incomplete grounding may cause electric shocks.
 - Gas pipes: Fire or an explosion might occur if the gas leaks.
 - Water pipes: Hard vinyl tubes are not effective grounds.
 - Lightning conductors or telephone ground wires: Electrical threshold may rise abnormally if struck by a lightning bolt.
- Install the power wire at least 3 feet (1 meter) away from televisions or radios to prevent interference or noise. (Depending on the radio waves, a distance of 3 feet (1 meter) may not be sufficient to eliminate the noise.)
- Do not wash the unit. This may cause electric shocks or fire. The appliance must be installed in accordance with national wiring regulations. If the supply cord is damaged, it must be replaced by the manufacturer, its service agent or similarly qualified persons in order to avoid a hazard.

- Do not install the unit in the following places:
 - Where there is mist of mineral oil, oil spray or vapors. Plastic parts may deteriorate, and cause them to come loose or water to leak.
 - Where corrosive gases (such as sulphurous acid gas) are produced. Where corrosion of copper pipes or soldered parts may cause refrigerant to leak.
 - Where there is machinery which emits electromagnetic waves. Electromagnetic waves can disturb the control system and cause equipment malfunction.
 - Where flammable gases may leak, where carbon fiber or ignitable dust is suspended in the air or where volatile flammables such as paint thinner or gasoline are handled. These types of gases might cause a fire.
 - Where the air contains high levels of salt such as near the ocean.
 - Where voltage fluctuates a lot, such as in factories.
 - In vehicles or vessels.
 - Where acidic or alkaline vapors are present.
- This appliance can be used by children 8 years old and above and persons with reduced physical, sensory or mental capabilities or lack of experience and knowledge if they are supervised or given instruction on using the unit in a safe manner and understand the hazards involved. Children should not play with the unit. Cleaning and user maintenance should not be done by children without supervision.
- Children should be supervised to ensure that they do not play with the appliance.
If the supply cord is damaged, it must be replaced by the manufacturer or its service agent or a similarly qualified person.
- DISPOSAL: Do not dispose this product as unsorted municipal waste. Collection of such waste separately for special treatment is necessary. Do not dispose of electrical appliances as municipal waste, use separate collection facilities. Contact your local government for information regarding the collection systems available. If electrical appliances are disposed of in landfills or dumps, hazardous substance can leak into the groundwater and get into the food chain, damaging your health and well-being.
- The wiring must be performed by professional technicians in accordance with national wiring regulation and this circuit diagram. An all-pole disconnection device which has at least 3mm separation distance in all pole and a residualcurrent device(RCD) with the rating not exceeding 30mA shall be incorporated in the fixed wiring according to the national rule.
- Confirm the safety of the installation area (walls, floors, etc.) without hidden dangers such as water, electricity, and gas. Before wiring/pipes.
- Before installation , check whether the user's power supply meets the electrical installation requirements of unit (including reliable grounding , leakage , and wire diameter electrical load, etc.). If the electrical installation requirements of the product are not met, the installation of the product is prohibited until the product is rectified.
- When installing multiple air conditioners in a centralized manner, please confirm the load balance of the three-phase power supply, and multiple units are prevented from being assembled into the same phase of the three-phase power supply.
- Product installation should be fixed firmly, Take reinforcement measures, when necessary.

NOTE

- About Fluorinated Gasses
 - This air-conditioning unit contains fluorinated gasses. For specific information on the type of gas and the amount, please refer to the relevant label on the unit itself. Compliance with national gas regulations shall be observed.
 - Installation, service, maintenance and repair of this unit must be performed by a certified technician.
 - Product uninstallation and recycling must be performed by a certified technician.
 - If the system has a leak-detection system installed, it must be checked for leaks at least every 12 months. When the unit is checked for leaks, proper record-keeping of all checks is strongly recommended.

2 GENERAL INTRODUCTION

- These units are used for both heating and cooling applications. They can be combined with fan coil units, floor heating applications, low temperature high efficiency radiators, domestic hot water tanks (field supply) and solar kits (field supply).
- A wired controller is supplied with the unit .
- If you choose the built-in backup heater unit, the backup heater can increase the heating capacity during cold outdoor temperatures. The backup heater also serves as a backup in case of malfunctioning and for freeze protection of the outside water piping during winter time. The capacity of backup heater for different units is listed below.

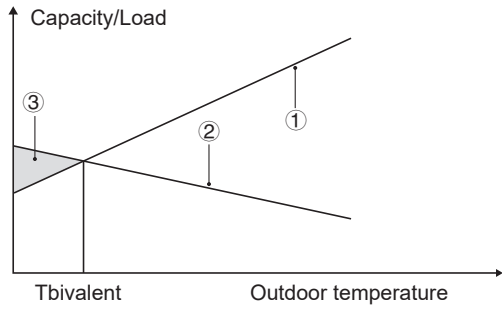

- ① Heat pump capacity.
- ② Required heating capacity (site dependent).
- ③ Additional heating capacity provided by backup heater.

- Domestic hot water tank (field supply)

A domestic hot water tank(with or without booster heater) can be connected to the unit.

The requirement of the tank is different for different unit and material of heat exchanger.

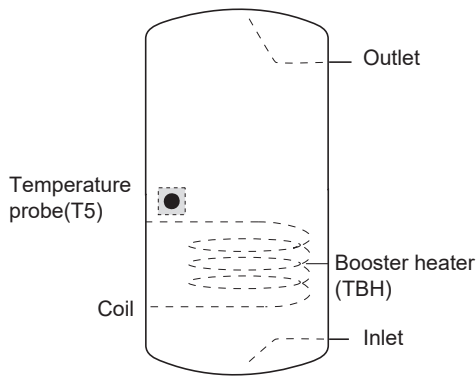

If the tank volume is greater than 240L, the temperature probe (T5) should be installed at a position higher than half of the tank's height.

If the tank volume is less than 240L, the temperature probe should be installed at a position higher than 2/3 of the tank's height.

The booster heater should be installed below the temperature probe.

The heat exchanger (coil) should be installed below the temperature probe.

The pipe length between the outdoor unit and tank should be less than 5 meters.

Unit		5~9 kW	12~16 kW	
Volume of tank/L	Minimum	100	200	
	Recommended	200	300	
Heat exchanger (Stainless steel coil)	Heat exchange area/m ²	Minimum	1.4	1.75
		Recommended	2.5	4
	Volume/L	Minimum	12	14
		Recommended	20	32
Heat exchanger (Enamel coil)	Heat exchange area/m ²	Minimum	1.7	2.5
		Recommended	3	5.6
	Volume/L	Minimum	14	20
		Recommended	24	45

- Room thermostat(field supply)

Room thermostat can be connected to the unit(room thermostat should be kept away from heating source when selecting the installation place).

- Solar kit for domestic hot water tank(field supply)

An optional solar kit can be connected to the unit.

- Remote alarm kit(field supply)

A remote alarm kit can be connected to the unit.

- Operation range

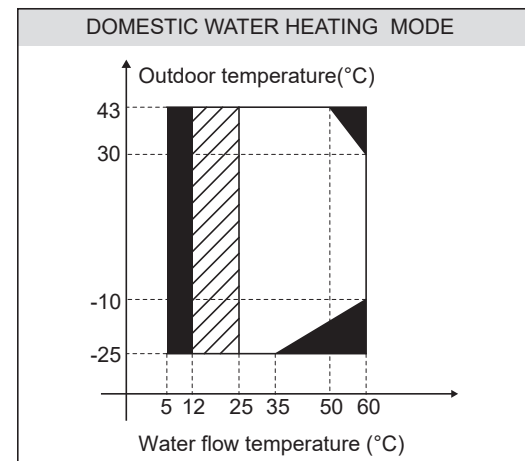
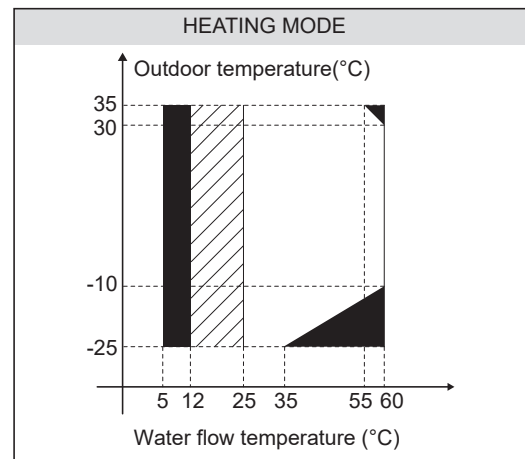
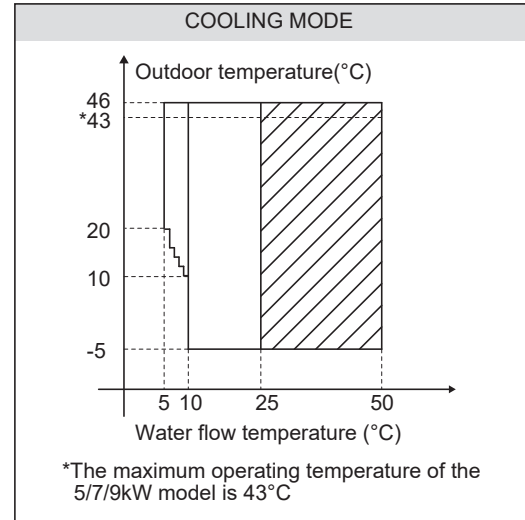

■ No heat pump operation, backup heater or boiler only

▨ Water flow temperature drop or rise interval

The unit have a freeze prevention function that uses the heat pump and backup heater (Customized model) to keep the water system safe from freezing in all conditions. Since a power failure may happen when the unit is unattended, It's suggested to use anti-freezing flow switch in the water system. (Refer to 9.4 Water piping).

In cooling mode, the minimum leaving water flow temperature(T1stoph) that the unit can reach in different outdoor temperature(T4) is listed below:

Outdoor temp. (°C)	≤10	11	12	13
Water flow temp. (°C)	10	9	9	8
Outdoor temp. (°C)	14	15	16	17
Water flow temp. (°C)	8	7	7	6
Outdoor temp. (°C)	18	19	20	≥21
Water flow temp. (°C)	6	6	5	5

In heating mode, the maximum leaving water flow temperature (T1stoph) that heat pump can reach in different outdoor temperature (T4) is listed below:

Outdoor temp. (°C)	-25	-24	-23	-22
Water flow temp. (°C)	35	35	35	37
Outdoor temp. (°C)	-21	-20	-19	-18
Water flow temp. (°C)	39	40	42	44
Outdoor temp. (°C)	-17	-16	-15	-14
Water flow temp. (°C)	46	48	50	52
Outdoor temp. (°C)	-13	-12	-11	-10~30
Water flow temp. (°C)	54	56	58	60
Outdoor temp. (°C)	31	32	33	34
Water flow temp. (°C)	59	58	57	56
Outdoor temp. (°C)	35	36	37	38
Water flow temp. (°C)	55	55	55	55
Outdoor temp. (°C)	39	40	41	42
Water flow temp. (°C)	54	53	52	51
Outdoor temp. (°C)	43	44	45	46
Water flow temp. (°C)	50	50	50	50

In DHW mode, the maximum domestic hot water temperature(T5stop) that heat pump can reach in different outdoor temperature(T4) is listed below:

Outdoor temp. (°C)	-25~-16	-15~-11	-10~-6	-5~-1	
DHW Water flow temp. (°C)	5~9kW	45	48	50	52
	12~16kW	40	45	48	50
Outdoor temp. (°C)	0~4	5~14	15~19	20~24	
DHW Water flow temp. (°C)	5~9kW	55	55	55	52
	12~16kW	53	55	55	50
Outdoor temp. (°C)	25~29	30~34	35~39	40~43	
DHW Water flow temp. (°C)	5~9kW	50	50	48	45
	12~16kW	50	48	48	45

4 BEFORE INSTALLATION

• Before installation











Be sure to confirm the model name and the serial number of the unit.

• Handling

Due to relatively large dimensions and heavy weight, the unit should only be handled using lifting tools with slings. The slings can be fitted into foreseen sleeves at the base frame that are made specifically for this purpose.



3 ACCESSORIES

3.1 Accessories supplied with the unit

Installation Fittings			
Name	Shape	Quantity	
		5~9kW	12~16kW
Installation and owner's manual(this book)		1	1
Operation manual		1	1
Technical data manual		1	1
Y-shape filter		1	1
Water outlet connection pipe assembly		2	1
Wired controller		1	1
Tighten belt for customer wiring use		0	2
		3	3
Thermistor for domestic hot water tank or additional heating source*		1	1
Extension wire for T5		1	1

The thermistor can be used to detect temperature of water.If domestic hot water tank is installed only, the thermistor can work as T5. If boiler is installed only, the thermistor can work as T1B. If both unit are installed, an additional thermistor is needed(please contact the supplier).The thermistor should connect to the corresponding port in the main control board of hydraulic(refer to 9.3.1Main control board of hydraulic module).

3.2 Accessories available from supplier

NAME	SHAPE
Water temperature thermistor(T1B)	
Extension wire(for T1B)	

⚠ CAUTION

- To avoid injury, do not touch the air inlet or aluminum fins of the unit.
- Do not use the grips in the fan grills to avoid damage.
- The unit is top heavy! Prevent the unit from falling due to improper inclination during handling.

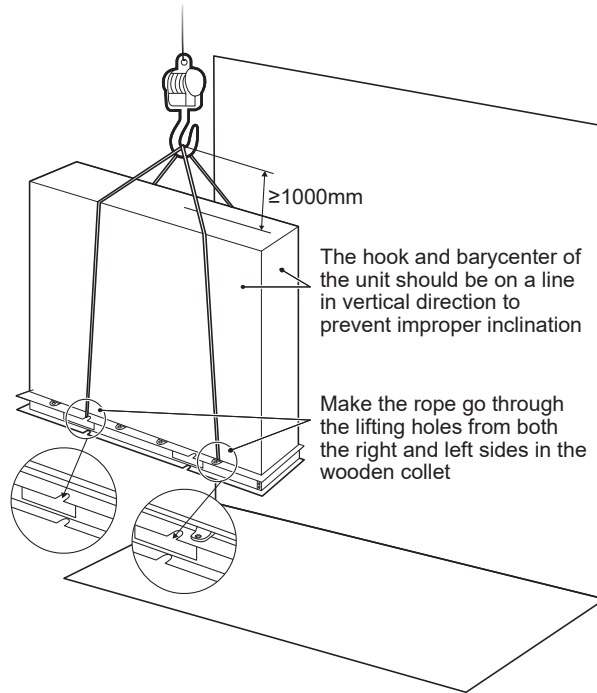

The position of barycenter for different unit can be seen in the picture below.

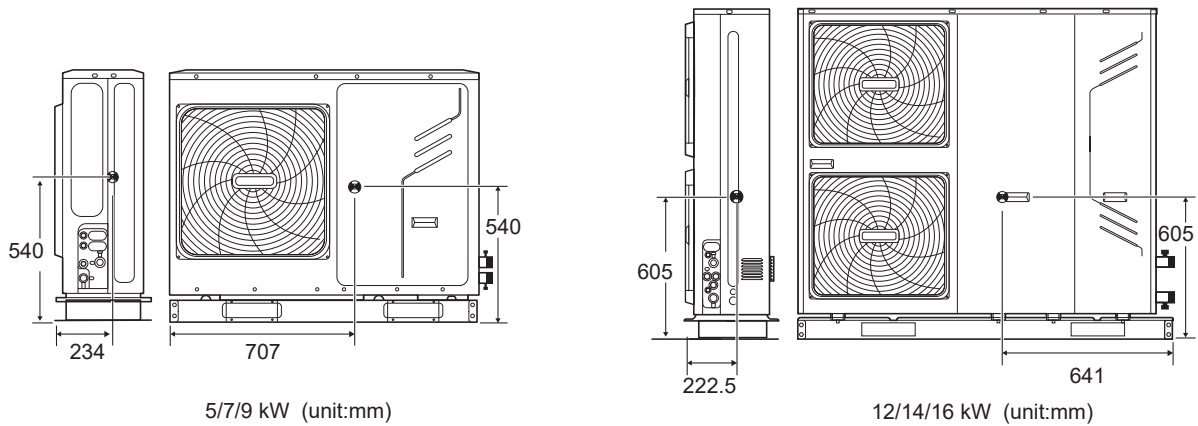

5 IMPORTANT INFORMATION FOR THE REFRIGERANT

This product has the fluorinated gas, it is forbidden to release to air.

Refrigerant type: R32; Volume of GWP: 675.

GWP=Global Warming Potential

Model	Factory charged refrigerant volume in the unit	
	Refrigerant/kg	Tonnes CO ₂ equivalent
5kW	2.00	1.35
7kW	2.00	1.35
9kW	2.00	1.35
12kW	2.80	1.89
14kW	2.80	1.89
16kW	2.80	1.89

CAUTION

- Frequency of Refrigerant Leakage Checks
 - For unit that contains fluorinated greenhouse gases in quantities of 5 tonnes of CO₂ equivalent or more, but of less than 50 tonnes of CO₂ equivalent, at least every 12 months, or where a leakage detection system is installed, at least every 24 months.
 - For unit that contains fluorinated greenhouse gases in quantities of 50 tonnes of CO₂ equivalent or more, but of less than 500 tonnes of CO₂ equivalent at least every six months, or where a leakage detection system is installed, at least every 12 months.
 - For unit that contains fluorinated greenhouse gases in quantities of 500 tonnes of CO₂ equivalent or more, at least every three months, or where a leakage detection system is installed, at least every six months.
 - This air-conditioning unit is a hermetically sealed equipment that contains fluorinated greenhouse gases.
 - Only certificated person is allowed to do installation, operation and maintenance.

6 INSTALLATION SITE

WARNING

- There is flammable refrigerant in the unit and it should be installed in a well-ventilated site. If the unit is installed inside, an additional refrigerant detection device and ventilation equipment must be added in accordance with the standard EN378. Be sure to adopt adequate measures to prevent the unit from being used as a shelter by small animals.
 - Small animals making contact with electrical parts can cause malfunction, smoke or fire. Please instruct the customer to keep the area around the unit clean.
-
- Select an installation site where the following conditions are satisfied and one that meets with your customer's approval.
 - Places that are well-ventilated.
 - Places where the unit does not disturb next-door neighbors.
 - Safe places which can bear the unit's weight and vibration and where the unit can be installed at an even level.
 - Places where there is no possibility of flammable gas or product leak.
 - The equipment is not intended for use in a potentially explosive atmosphere.
 - Places where servicing space can be well ensured.
 - Places where the units' piping and wiring lengths come within the allowable ranges.
 - Places where water leaking from the unit cannot cause damage to the location (e.g. in case of a blocked drain pipe).
 - Places where rain can be avoided as much as possible.
 - Do not install the unit in places often used as a work space. In case of construction work (e.g. grinding etc.) where a lot of dust is created, the unit must be covered.
 - Do not place any object or equipment on top of the unit (top plate)
 - Do not climb, sit or stand on top of the unit.
 - Be sure that sufficient precautions are taken in case of refrigerant leakage according to relevant local laws and regulations.- Don't install the unit near the sea or where there is corrosion gas.
 - When installing the unit in a place exposed to strong wind, pay special attention to the following.
 - Strong winds of 5 m/sec or more blowing against the unit's air outlet causes a short circuit (suction of discharge air), and this may have the following consequences:
 - Deterioration of the operational capacity.
 - Frequent frost acceleration in heating operation.
 - Disruption of operation due to rise of high pressure.
 - When a strong wind blows continuously on the front of the unit, the fan can start rotating very fast until it breaks.

In normal condition, refer to the figures below for installation of the unit:

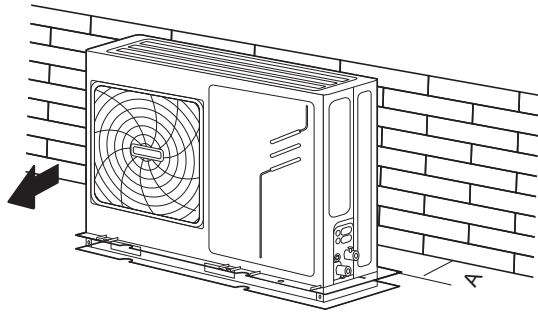

Unit	A(mm)
5~9kW	≥300
12~16kW	≥300

In case of strong wind and the wind direction can be foreseen, refer to the figures below for installation of the unit (any one is OK):

Turn the air outlet side toward the building's wall, fence or screen.

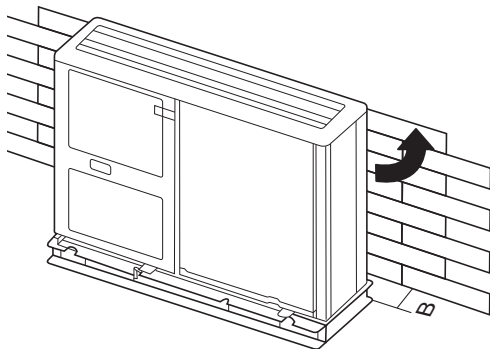

Unit	B(mm)
5~9kW	≥1000
12~16kW	≥1500

Make sure there is enough room to do the installation.

Set the outlet side at a right angle to the direction of the wind.

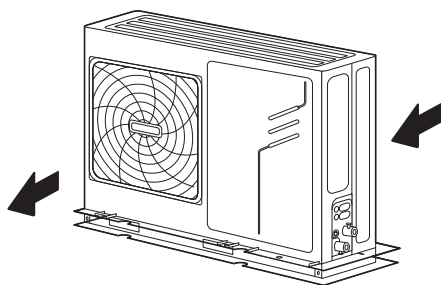

- Prepare a water drainage channel around the foundation, to drain waste water from around the unit.
- If water does not easily drain from the unit, mount the unit on a foundation of concrete blocks, etc. (the height of the foundation should be about 100 mm (3.93 in)).
- If you install the unit on a frame, please install a waterproof plate (about 100 mm) on the underside of the unit to prevent water from coming in from the low side.
- When installing the unit in a place frequently exposed to snow, pay special attention to elevate the foundation as high as possible.

- If you install the unit on a building frame, please install a waterproof plate (field supply) (about 100mm, on the underside of the unit) in order to avoid drain water dripping. (See the picture in the right).



NOTE

- Unit is top heavy!
- Try not to install on the building frame.

6.1 Selecting a location in cold climates

Refer to "Handling" in section "4 Before installation"

NOTE

When operating the unit in cold climates, be sure to follow the instructions described below.

- To prevent exposure to wind, install the unit with its suction side facing the wall.
- Never install the unit at a site where the suction side may be exposed directly to wind.
- To prevent exposure to wind, install a baffle plate on the air discharge side of the unit.
- In heavy snowfall areas, it is very important to select an installation site where the snow will not affect the unit. If lateral snowfall is possible, make sure that the heat exchanger coil is not affected by the snow (if necessary construct a lateral canopy).

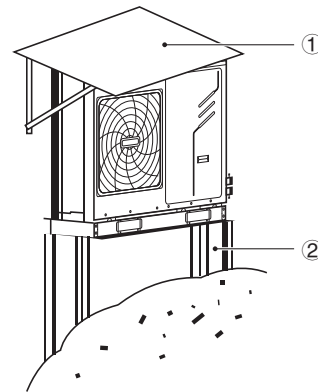

① Construct a large canopy.

② Construct a pedestal.

Install the unit high enough off the ground to prevent it from being buried in snow.

6.2 Selecting a location in hot climates

As the outdoor temperature is measured via the outdoor unit air thermistor, make sure to install the outdoor unit in the shade or a canopy should be constructed to avoid direct sunlight, so that it is not influenced by the sun's heat, otherwise protection may be possible to the unit.

7 INSTALLATION PRECAUTIONS

7.1 Dimensions

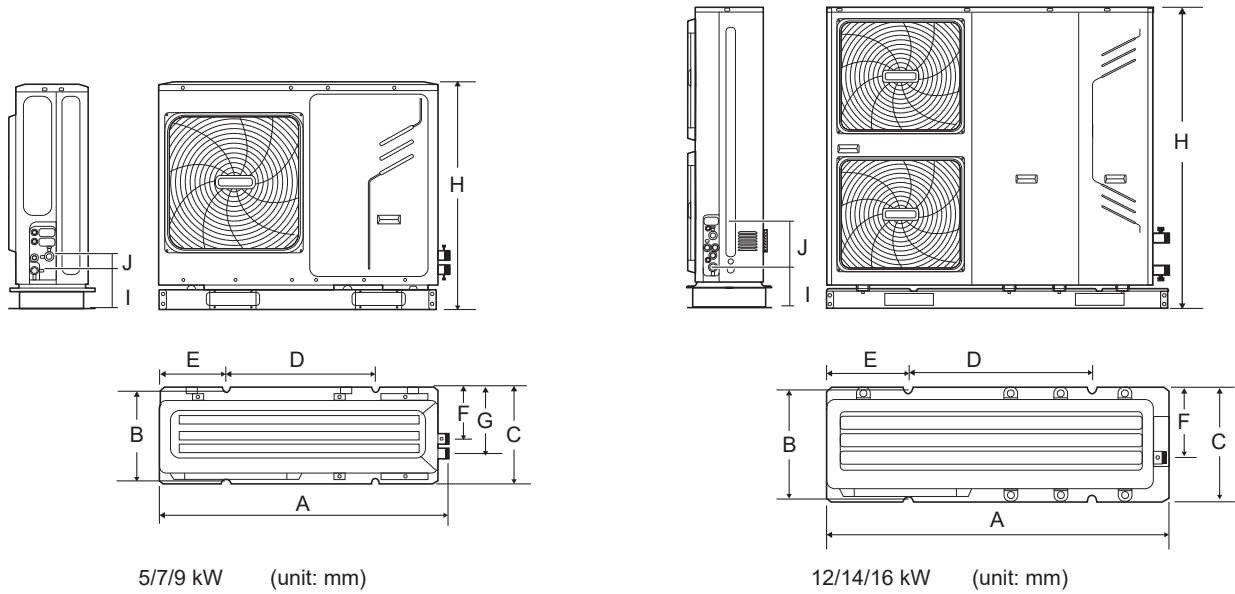

Model	A	B	C	D	E	F	G	H	I	J
5/7/9kW	1210	374	402	502	404	215	277	945	165	59
12/14/16kW	1404	373	405	760	361	280	/	1414	176	144

7.2 Installation requirements

- Check the strength and level of the installation ground so that the unit may not cause any vibrations or noise during its operation.
- In accordance with the foundation drawing in the figure, fix the unit securely by means of foundation bolts. (Prepare four sets each of $\Phi 10$ Expansion bolts, nuts and washers which are readily available in the market.)
- Screw in the foundation bolts until their length is 20 mm from the foundation surface.

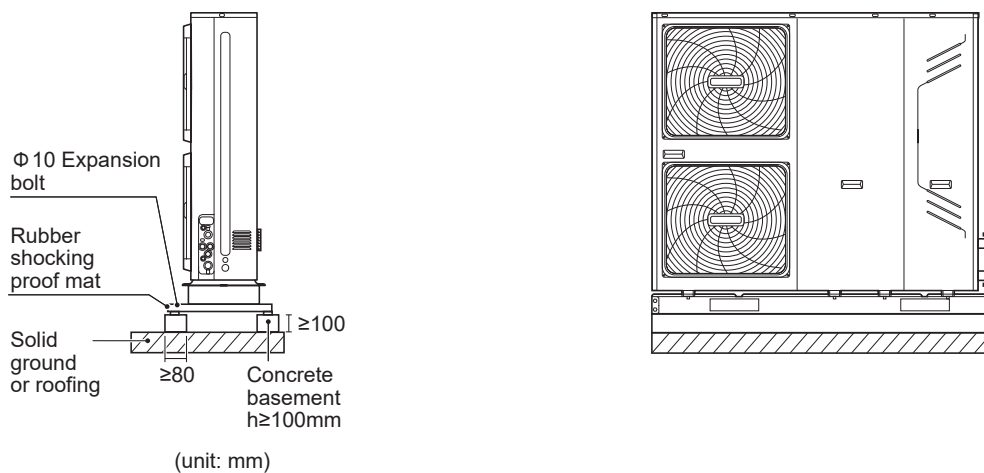

7.3 Drain hole position

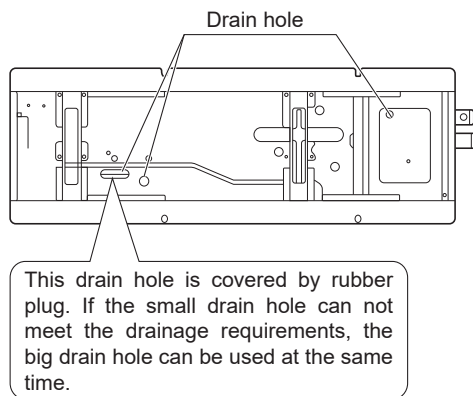

5/7/9 kW

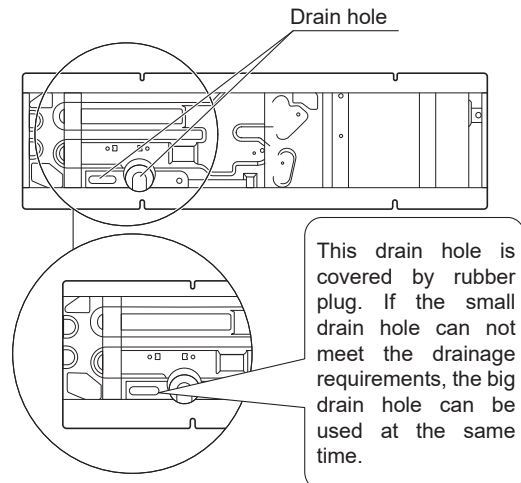

12/14/16 kW

NOTE

It's necessary to install an electrical heating belt if water can't drain out in cold weather even the big drain hole has opened.

7.4 Servicing space requirements

7.4.1 In case of stacked installation

1) In case obstacles exist in front of the outlet side.

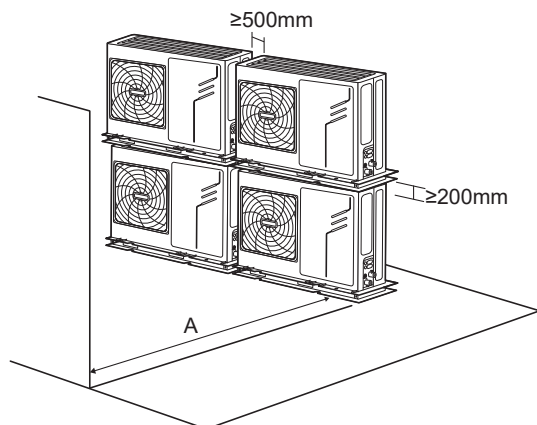

2) In case obstacles exist in front of the air inlet.

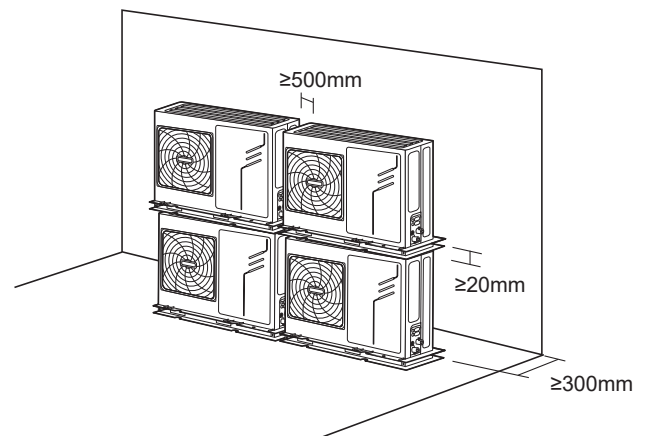

Unit	A(mm)
5~9kW	≥ 1000
12~16kW	≥ 1500

7.4.2 In case of multiple-row installation (for roof top use, etc.)

1) In case of installing one unit per row.

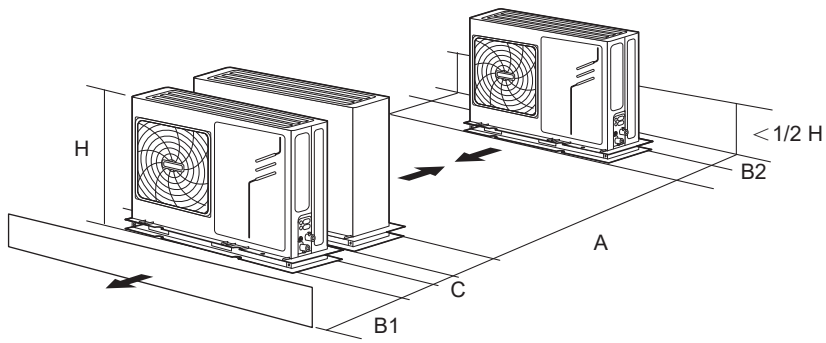

Unit	A(mm)	B1(mm)	B2(mm)	C(mm)
5~9kW	≥1500	≥500	≥150	≥300
12~16kW	≥2000	≥1000	≥150	≥300

2) In case of installing multiple units in lateral connection per row.

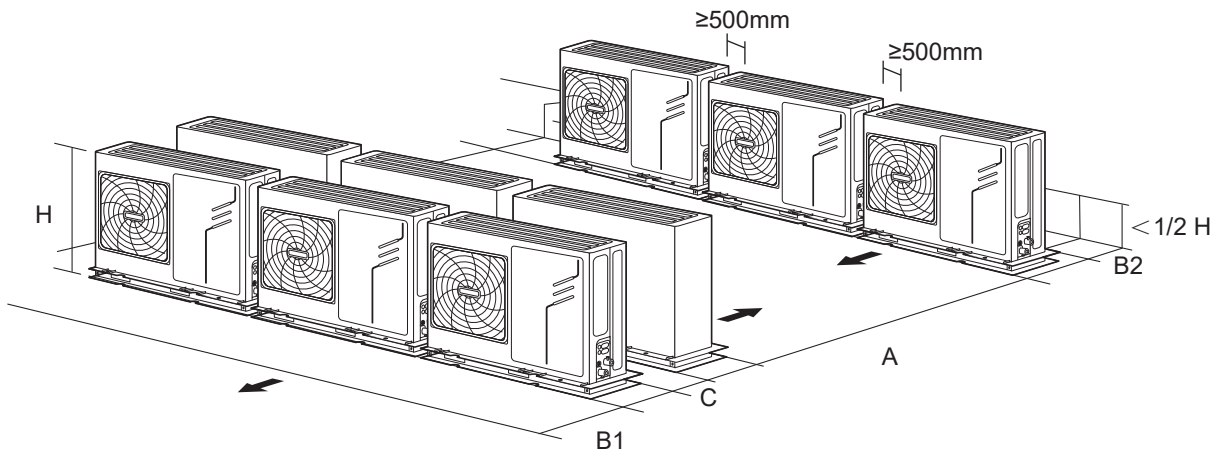

Unit	A(mm)	B1(mm)	B2(mm)	C(mm)
5~9kW	≥2500	≥1000	≥300	≥600
12~16kW	≥3000	≥1500	≥300	≥600

8 TYPICAL APPLICATIONS

The application examples given below are for illustration only.

8.1 Application 1

Space heating with a room thermostat connected to the unit.

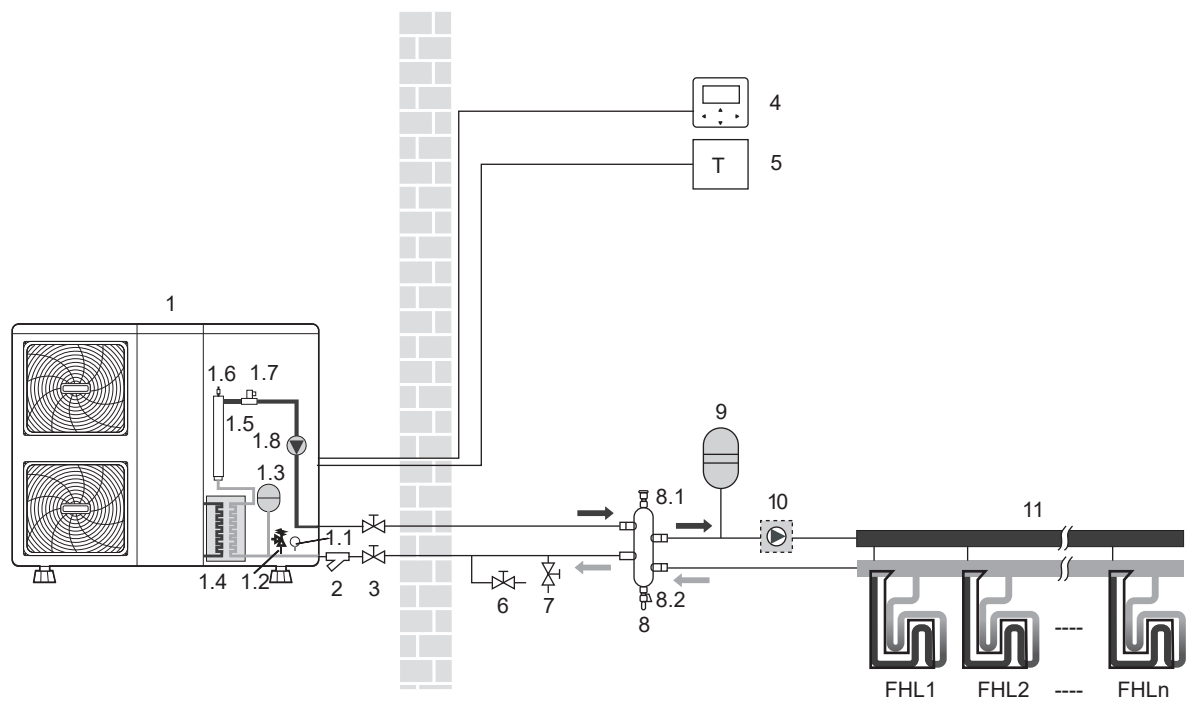

Coding	Assembly unit	Coding	Assembly unit
1	Outdoor unit	4	Wired controller
1.1	Manometer	5	Room thermostat (field supply)
1.2	Pressure relief valve	6	Drain valve (field supply)
1.3	Expansion vessel	7	Fill valve (field supply)
1.4	Plate heat exchanger	8	Balance tank (field supply)
1.5	Backup heater (Customized model)	8.1	Air purge valve
1.6	Air purge valve	8.2	Drain valve
1.7	Flow switch	9	Expansion vessel (field supply)
1.8	P _i : Circulation pump inside the unit	10	P _o : Outside circulation pump (field supply)
2	Y-shape filter	11	Collector (field supply)
3	Stop valve (field supply)	FHL 1...n	Floor heating loop (field supply)

NOTE

The volume of balance tank(8) should be greater than 40L(for 5~9kW unit, greater than 20L) The drain valve (6) should be installed at the lowest position of the system. An independent backup heater can be selected and installed in the door. Pump_o(10) should be controlled by outdoor unit and connect to corresponding port in the outdoor unit(refer to 9.7.6 Connection for other components/For outside circulation pump P_o).

Unit operation and space heating:

When a room thermostat is connected to the unit and when there is a heating request from the room thermostat, the unit will start operating to achieve the target water flow temperature as set on the user interface. When the room temperature is above the thermostat set point in the heating mode, the unit will stop operating. The circulation pump (1.8) and (10) will also stop running. The room thermostat is used as a switch here.

NOTE

Make sure to connect the thermostat wires to the correct terminals, method B should be selected (see "For room thermostat" in 9.7.6 connection for other components). To correctly configure the ROOM THERMOSTAT in the FOR SERVICEMAN mode see 10.7 Field settings/ROOM THERMOSTAT.

8.2 Application 2

Space heating without room thermostat connected to the unit. Domestic hot water is provided through the domestic hot water tank that is connected to the unit.

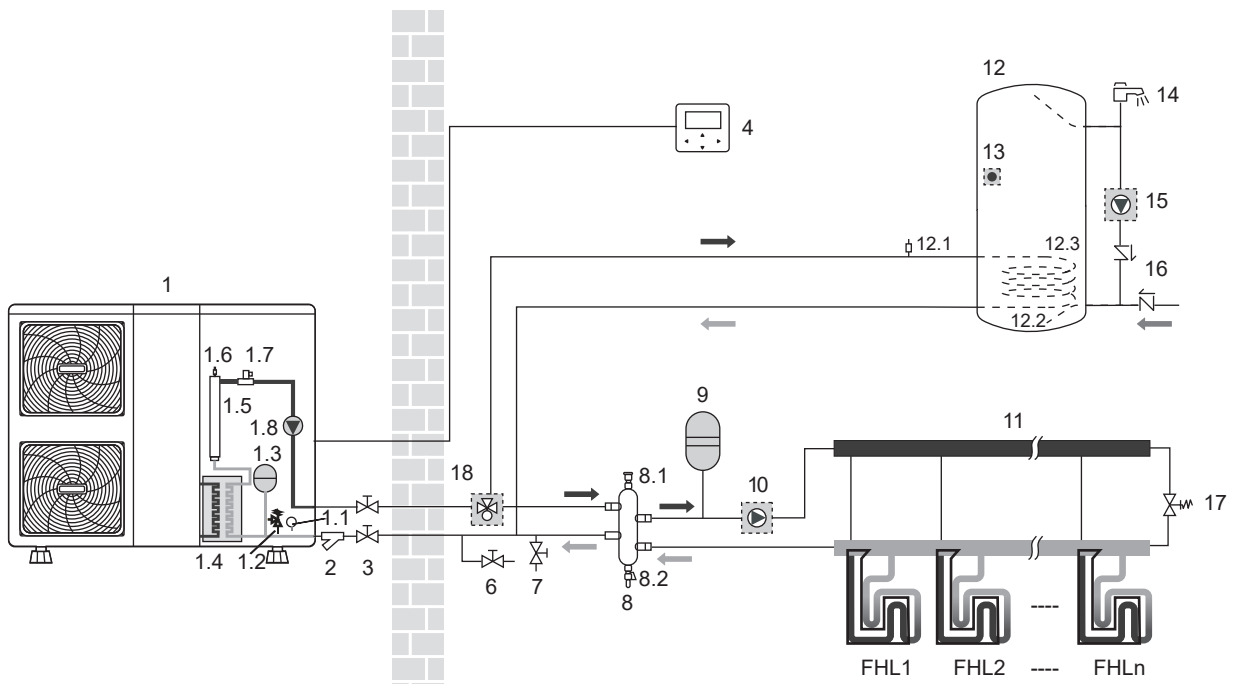

Coding	Assembly unit	Coding	Assembly unit
1	Outdoor unit	8.2	Drain valve
1.1	Manometer	9	Expansion vessel (field supply)
1.2	Pressure relief valve	10	P_o: Outside circulation pump (field supply)
1.3	Expansion vessel	11	Collector (field supply)
1.4	Plate heat exchanger	12	Domestic hot water tank (field supply)
1.5	Backup heater (Customized model)	12.1	Air purge valve
1.6	Air purge valve	12.2	Heat exchanger coil
1.7	Flow switch	12.3	Booster heater
1.8	P_i: Circulation pump inside the unit	13	T5: temperature sensor
2	Y-shape filter	14	Hot water tap (field supply)
3	Stop valve (field supply)	15	P_d: DHW pump (field supply)
4	Wired controller	16	One way valve (field supply)
6	Drain valve (field supply)	17	Bypass valve (field supply)
7	Fill valve (field supply)	18	SV1: 3-way valve (field supply)
8	Balance tank (field supply)	FHL 1...n	Floor heating loop (field supply)
8.1	Air purge valve	/	/

NOTE

The volume of balance tank(8) should be greater than 40L(for 5~9kW unit, greater than 20L) The drain valve (6) should be installed at the lowest position in the system. An independent backup heater can be selected and installed in the door. pump(10) should be controlled by outdoor unit and connect to corresponding port in the outdoor unit(refer to 9.7.6 Connection for other components/For outside circulation pump P_o).

• Circulation pump operation

The circulation pump (1.8) and (10) will operate as long as the unit is on for space heating.
The circulation pump (1.8) will operate as long as the unit is on for heating domestic hot water (DHW).

• Space heating

- 1) The unit (1) will operate to achieve the target water flow temperature set on the wired controller.
- 2) The bypass valve should be selected so that at all times the minimum water flow as mentioned in 9.4 Water piping is guaranteed.

• Domestic water heating

- 1) When the domestic water heating mode is enabled (either manually by the user, or automatically through scheduling) the target domestic hot water temperature will be achieved by a combination of the heat exchanger coil and the electrical booster heater (when the booster heater in the tank is set to YES).
- 2) When the domestic hot water temperature is below the user configured set point, the 3-way valve will be activated to heat the domestic water by means of the heat pump. If there is a huge demand for hot water or a high hot water temperature setting, the booster heater (12.1) can provide auxiliary heating.

⚠ CAUTION

Make sure to fit the 3-way valve correctly. For more details, refer to 9.7.6 Connection for other components/For 3-way valve SV1.

💡 NOTE

The unit can be configured so that at low outdoor temperatures, water is exclusively heated by the booster heater. This assures that the full capacity of the heat pump is available for space heating.

Details on domestic hot water tank configuration for low outdoor temperatures (T4DHWMIN) can be found in 10.7 Field settings/How to set the DHW MODE.

8.3 Application 3

Space cooling and heating application with a room thermostat suitable for heating/cooling changeover when connected to the unit. Heating is provided through floor heating loops and fan coil units. Cooling is provided through the fan coil units only. Domestic hot water is provided through the domestic hot water tank which is connected to the unit.

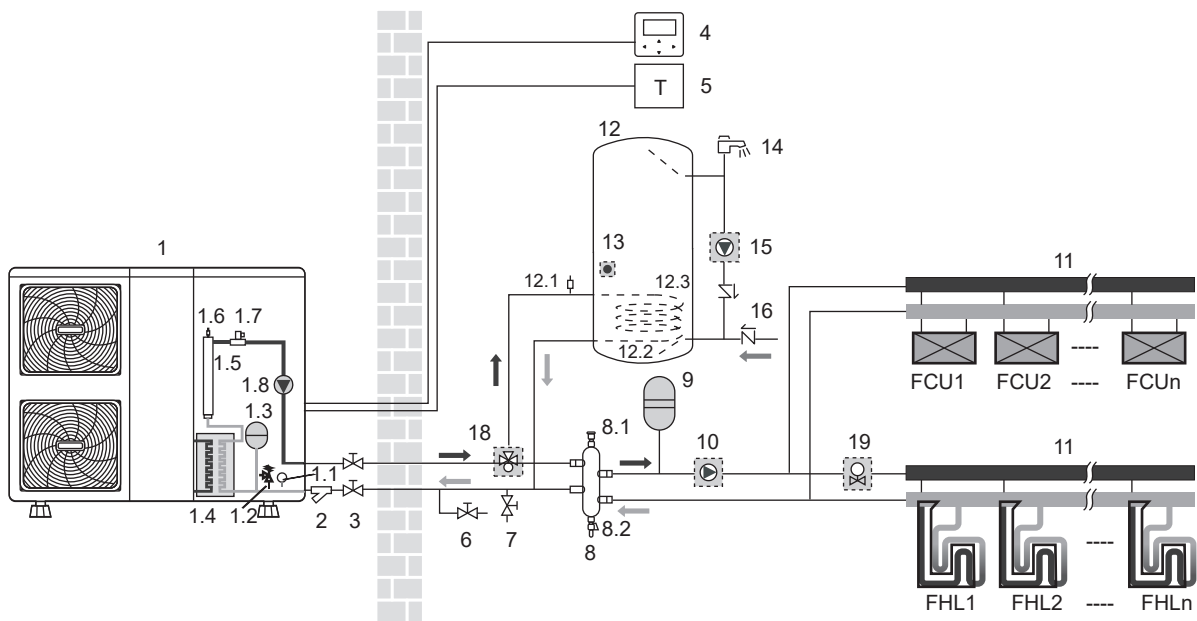

Coding	Assembly unit	Coding	Assembly unit
1	Outdoor unit	8.2	Drain valve
1.1	Manometer	9	Expansion vessel (field supply)
1.2	Pressure relief valve	10	P_o: Outside circulation pump (field supply)
1.3	Expansion vessel	11	Collector (field supply)
1.4	Plate heat exchanger	12	Domestic hot water tank (field supply)
1.5	Backup heater (Customized model)	12.1	Air purge valve
1.6	Air purge valve	12.2	Heat exchanger coil
1.7	Flow switch	12.3	Booster heater
1.8	P_i: Circulation pump inside the unit	13	T5: temperature sensor
2	Y-shape filter	14	Hot water tap (field supply)
3	Stop valve (field supply)	15	P_d: DHW pump (field supply)
4	Wired controller	16	One way valve (field supply)
5	Room thermostat (field supply)	18	SV1: 3-way valve (field supply)
6	Drain valve (field supply)	19	SV2: 2-way valve (field supply)
7	Fill valve (field supply)	FHL 1...n	Floor heating loop (field supply)
8	Balance tank (field supply)	FCU 1...n	Fan coil units (field supply)
8.1	Air purge valve	/	/

NOTE

The volume of balance tank(8) should be greater than 40L(for 5~9kW unit, greater than 20L) The drain valve (6) should be installed at the lowest position of the system. An independent backup heater can be selected and installed in the door.pump(10) should be controlled by outdoor unit and connect to corresponding port in the outdoor unit(refer to 9.7.6 Connection for other components/For outside circulation pump P_o).

• Pump operation and space heating and cooling

The unit will switch to either heating or cooling mode according to the setting of room thermostat. When space heating/cooling is requested by the room thermostat (5), the pump will start operating and the unit (1) will switch to heating mode/cooling mode. The unit (1) will operate to achieve the target cold/hot water leaving temperature. In the cooling mode, the motorized 2-way valve (19) will close to prevent cold water running through the floor heating loops (FHL).

CAUTION

Make sure to connect the thermostat wires to the correct terminals and to configure the ROOM THERMOSTAT in the wired controller correctly (see 10.7 Field settings/ROOM THERMOSTAT). Wiring of the room thermostat should follow method A as described in 9.7.6 connection for other components/For room thermostat.

Wiring of the 2-way valve (19) is different for a NC (normal closed) valve and a NO (normal open) valve! Make sure to connect to the correct terminal numbers as detailed on the wiring diagram.

The ON/OFF setting of the heating/cooling operation cannot be done on the user interface, the target outlet water temperature should be set in the user interface.

• Domestic water heating

Domestic water heating is as described in 8.2 Application 2.

8.4 Application 4

Space cooling and heating without a room thermostat connected to the unit. The temperature sensor Ta attached in the user interface is used to control the ON/OFF of the unit. Heating is provided through floor heating loops and fan coil units. Cooling is provided through fan coil units only.

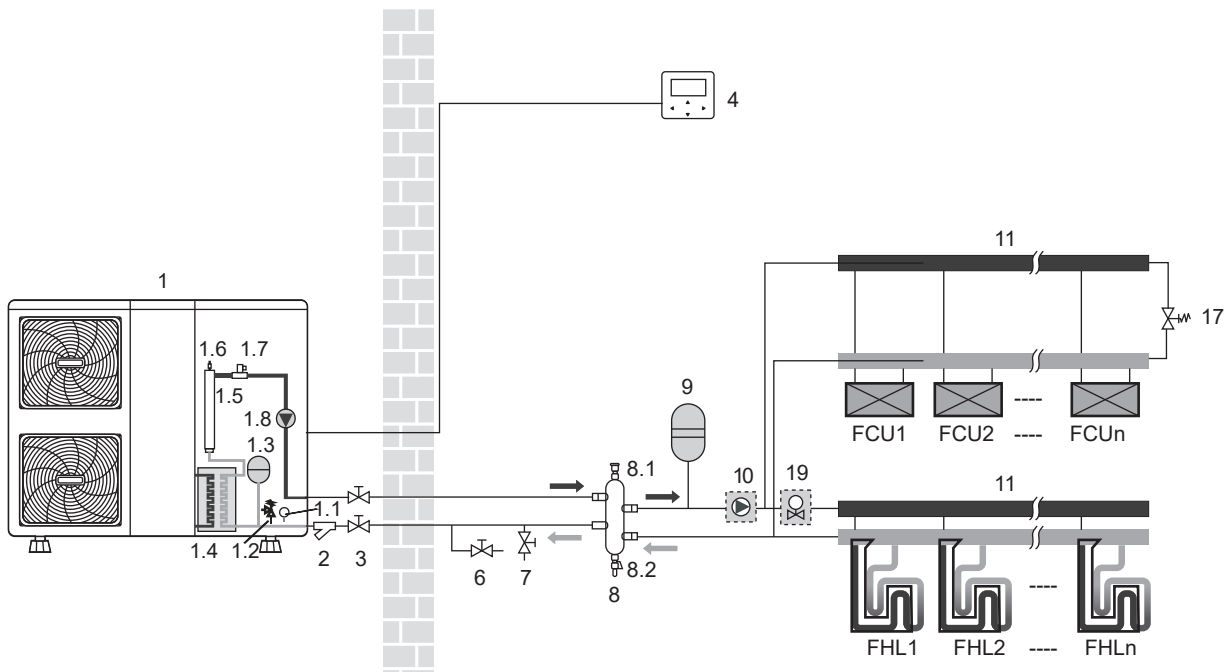

Coding	Assembly unit	Coding	Assembly unit
1	Outdoor unit	6	Drain valve (field supply)
1.1	Manometer	7	Fill valve (field supply)
1.2	Pressure relief valve	8	Balance tank (field supply)
1.3	Expansion vessel	8.1	Air purge valve
1.4	Plate heat exchanger	8.2	Drain valve
1.5	Backup heater (Customized model)	9	Expansion vessel (field supply)
1.6	Air purge valve	10	P_o: Outside circulation pump (field supply)
1.7	Flow switch	11	Collector (field supply)
1.8	P_i: Circulation pump in the unit	17	Bypass valve (field supply)
2	Y-shape filter	19	SV2: 2-way valve (field supply)
3	Stop valve (field supply)	FHL 1...n	Floor Heating Loop (field supply)
4	Wired controller	FCU 1...n	Fan coil units (field supply)

NOTE

The volume of balance tank(8) should be greater than 40L(for 5~9kW unit, greater than 20L) The drain valve (6) should be installed at the lowest position of the system. An independent backup heater can be selected and installed in the door. pump(10) should be controlled by outdoor unit and connect to corresponding port in the outdoor unit(refer to 9.7.6 Connection for other components/For outside circulation pump P_o).

• Pump operation

The circulation pump (1.8) and (10) will operate as long as the unit is on for space heating.

NOTE

As the temperature sensor is used to detect the room temperature, the user interface (4) should be placed in a room where floor heating loops and fan coil units is installed and away from the heating source. Correct configuration should be applied in the user interface (refer to 10.7 field settings/TEMP. TYPE SETTING). The target room temperature can be set on the main page of user interface, the target outlet water temperature will be calculated from climate related curves, the unit will turn off when the room temperature reaches the target temperature.

• Space heating and cooling

According to the season, the customer selects cooling or heating through the user interface. The unit (1) will operate in cooling mode or heating mode to achieve the target room temperature. In heating mode, the 2-way valve (19) will open. Hot water is provided to both the fan coil units and the floor heating loops. In cooling mode, the motorized 2-way valve (19) is closed to prevent cold water running through the floor heating loops (FHL).

CAUTION

Wiring of the 2-way valve (19) is different for a NC (normal closed) valve and a NO (normal open) valve. The NO valve is unavailable to this unit. Make sure to connect to the correct terminal numbers as detailed on the wiring diagram.

The ON/OFF setting of the heating/cooling operation is done by the user interface.

8.5 Application 5

Space heating with an auxiliary boiler (alternating operation).

Space heating application by either the unit or by an auxiliary boiler connected in the system.

- The unit controlled contact (also called "permission signal for the auxiliary boiler") is determined by the outdoor temperature (thermistor located at the outdoor unit). See 10.7 Field settings/OTHER HEATING SOURCE.
- Bivalent operation is possible for both space heating operation and domestic water heating operation.
- If the auxiliary boiler only provides heat for space heating, the boiler must be integrated in the piping work and in the field wiring according to the illustration for application a.
- If the auxiliary boiler is also providing heat for domestic hot water, the boiler can be integrated in the piping work and in the field wiring according to the illustration for application b. In this condition, the unit can sent ON/OFF signal to boiler in heating mode, but the boiler control itself in DHW mode.
- If the auxiliary boiler only provides heat for domestic water heating, the boiler must be integrated in the piping work and in the field wiring according to the illustration for application c.

CAUTION

Be sure that the boiler and the integration of the boiler in the system is in accordance with relevant local laws and regulations.

8.5.1 Application a

Boiler provide heat for space heating only

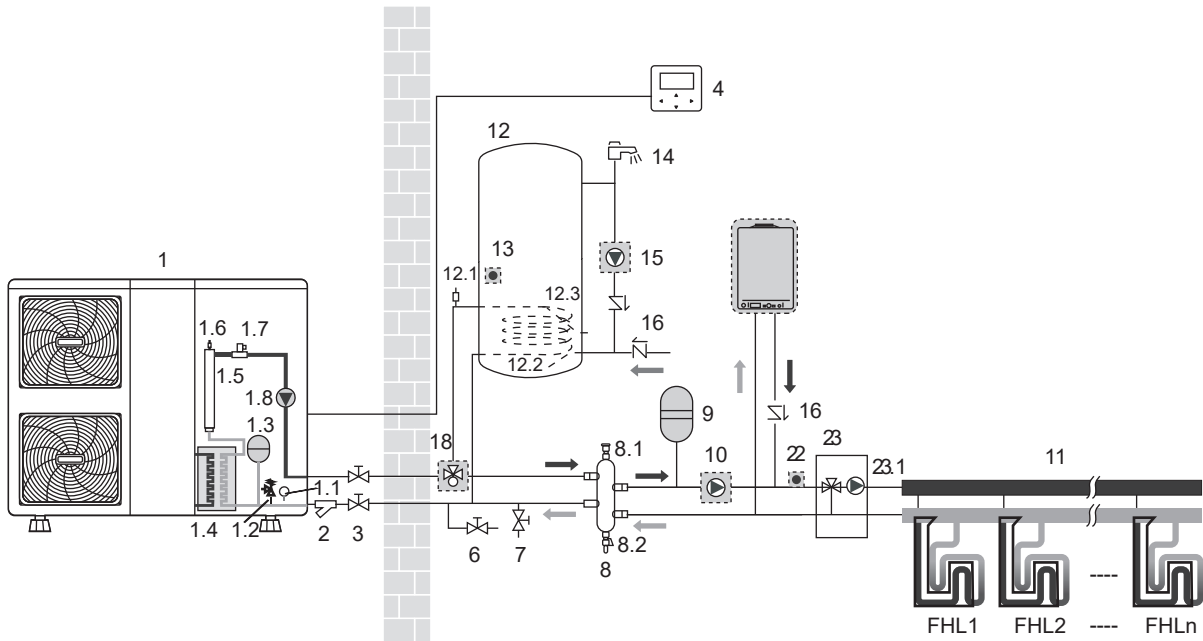

8.5.2 Application b

Boiler provide heat for space heating and domestic water heating, the ON/OFF of boiler is controlled by itself for domestic water heating.

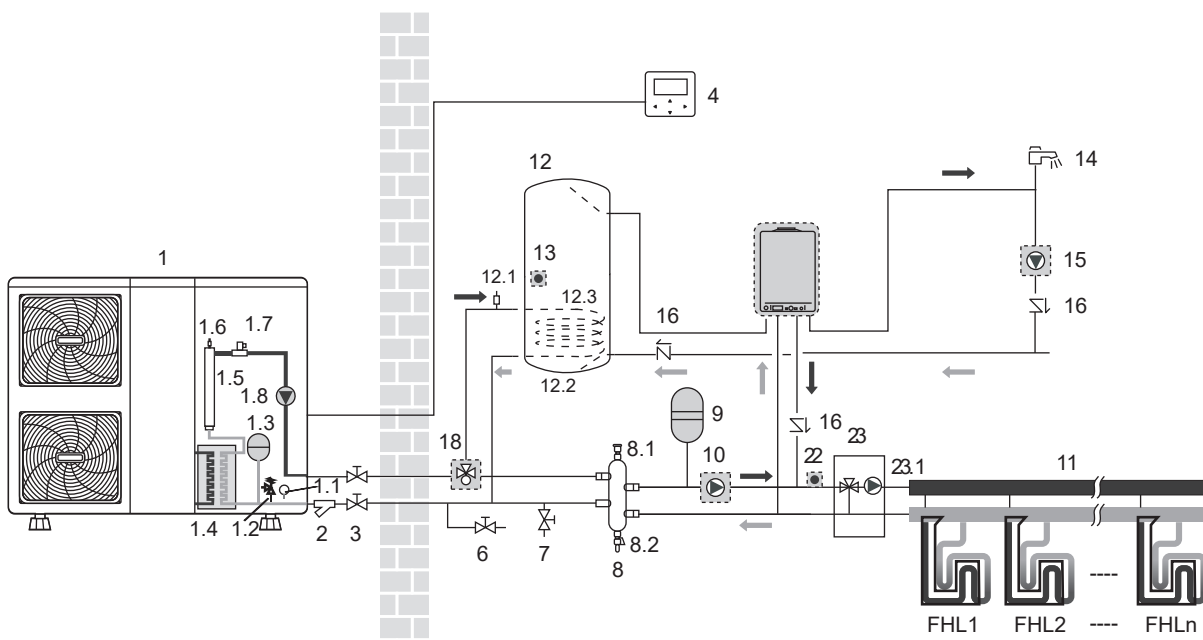

8.5.3 Application c

Boiler provide heat for space heating and domestic water heating. The ON/OFF of boiler controlled by unit.

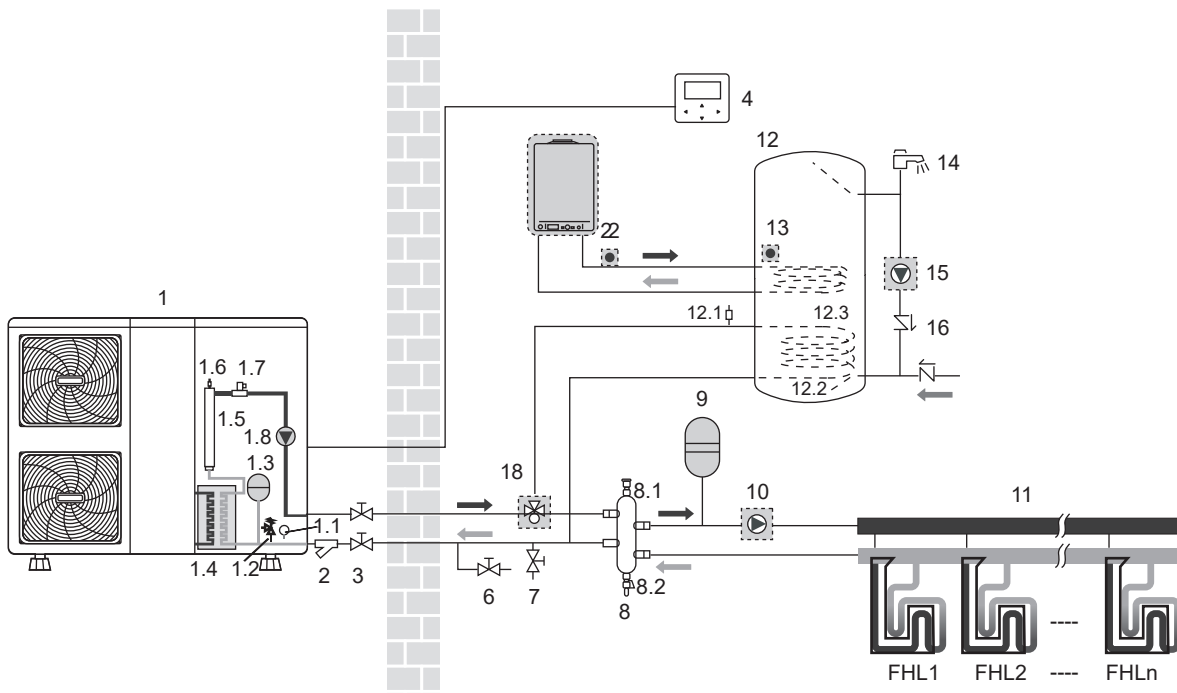

Coding	Assembly unit	Coding	Assembly unit
1	Outdoor unit	9	Expansion vessel (field supply)
1.1	Manometer	10	P_o: Outside circulation pump (field supply)
1.2	Pressure relief valve	11	Collector (field supply)
1.3	Expansion vessel	12	Domestic hot water tank (field supply)
1.4	Plate heat exchanger	12.1	Air purge valve
1.5	Backup heater (Customized model)	12.2	Heat exchanger coil
1.6	Air purge valve	12.3	Booster heater
1.7	Flow switch	13	T5: Temperature sensor
1.8	P_i: Circulation pump inside the unit	14	Hot water tap (field supply)
2	Y-shape filter	15	P_d: DHW pump (field supply)
3	Stop valve (field supply)	16	One way valve (field supply)
4	Wired controller	18	SV1: 3-way valve (field supply)
6	Drain valve (field supply)	22	T1B: Temperature sensor(field supply)
7	Fill valve (field supply)	23	Mixing station(field supply)
8	Balance tank (field supply)	23.1	P_c: Mixing pump
8.1	Air purge valve	FHL 1...n	Floor heating loop(field supply)
8.2	Drain valve	AHS	Additional heating source(boiler)(field supply)

NOTE

The volume of balance tank(8) should be greater than 40L(for 5~9kW unit, greater than 20L) The drain valve (6) should be installed at the lowest position of the system. An independent backup heater can be selected and installed in the door. Temperature sensor T1B must be installed at the outlet of AHS, and connect to the corresponding port in the main control board of hydraulic module(refer to 9.3.1 Main control board of hydraulic module), pump(10) should be controlled by outdoor unit and connect to corresponding port in the outdoor unit(refer to 9.7.6 Connection for other components/For outside circulation pump P_o).

Operation

When heating is required, either the unit or the boiler starts operating, depending on the outdoor temperature (refer to 10.7 field setting/OTHER HEATING SOURCE).

- As the outdoor temperature is measured via the outdoor unit air thermistor, make sure to install the outdoor unit in the shade, so that it is not influenced by the sun's heat.
- Frequent switching can cause corrosion of the boiler at an early stage. Contact the boiler manufacturer.
- During heating operation of the unit, the unit will operate to achieve the target water flow temperature set on the user interface. When weather dependent operation is active, the water temperature is determined automatically depending on the outdoor temperature.
- During heating operation of the boiler, the boiler will operate to achieve the target water flow temperature set on the user interface.
- Never set the target water flow temperature set point on the user interface above (60°C).

NOTE

Make sure to correctly configure FOR SERVICEMAN in the user interface. Refer to 10.7 Field settings/Other heating source.

CAUTION

Ensure that return water to the heat exchanger does not exceed 60°C. Never put the target water flow temperature set point on the user interface above 60°C.

Make sure that the non-return valves (field supply) are correctly installed in the system.

The supplier will not be held liable for any damage resulting from failure to observe this rule.

8.6 Application 6

Dual setpoint function application with two room thermostat connect to the outdoor unit.

- Space heating with two room thermostat application through floor heating loops and fan coil units. The floor heating loops and fan coil units require different operating water temperatures.
- The floor heating loops require a lower water temperature in heating mode compared to fan coil units. To achieve these two set points, a mixing station is used to adapt the water temperature according to requirements of the floor heating loops. The fan coil units are directly connected to the unit water circuit and the floor heating loops are after the mixing station. Control of this mixing station is not done by the unit.
- The operation and configuration of the field water circuit is the responsibility of the installer.
- We only offer a dual set point control function. This function allows two set points to be generated. Depending on the required water temperature (floor heating loops and/or fan coil units are required) the first set point(set on the user interface) or second set point(calculate from climate related curves) can be activated. More details refer to 10.7 field setting /ROOM THERMOSTAT.

NOTE

The wiring of room thermostat 5A(for fan coil units) and 5B(for floor eating loops) should follow 'method C' as described in 9.7.6 Connection for other components/For room thermostat, and the thermostat which connect to port 'C' (in the outdoor unit) should be placed on the zone where floor heating loops is installed(zone B), the other one connect to port 'H' should be placed on the zone where fan coil units are installed(zone A).

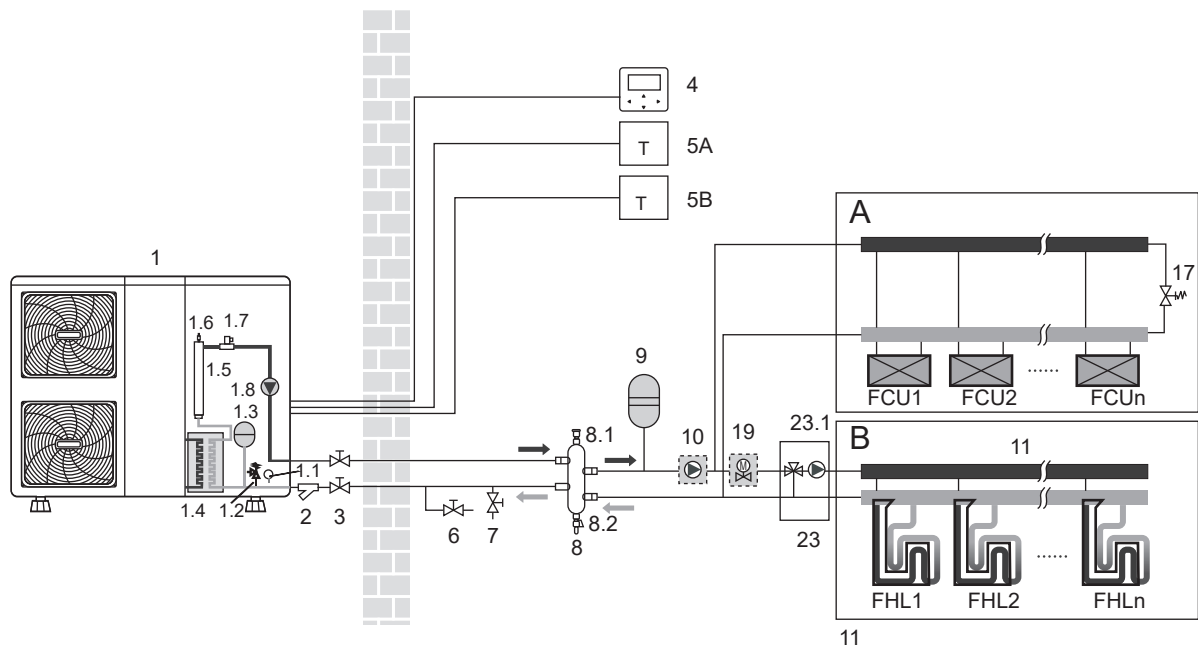

Coding	Assembly unit	Coding	Assembly unit
1	Outdoor unit	7	Fill valve (field supply)
1.1	Manometer	8	Balance tank (field supply)
1.2	Pressure relief valve	8.1	Air purge valve
1.3	Expansion vessel	8.2	Drain valve
1.4	Plate heat exchanger	9	Expansion vessel (field supply)
1.5	Backup heater (Customized model)	10	P_o: Outside circulation pump (field supply)
1.6	Air purge valve	11	Collector (field supply)
1.7	Flow switch	17	Bypass valve (field supply)
1.8	P_i: Circulation pump in the unit	19	SV2:2-way valve (field supply)
2	Y-shape filter	23	Mixing station (field supply)
3	Stop valve (field supply)	23.1	P_c: mixing pump
4	Wired controller	FHL 1...n	Floor heating loop (field supply)
6	Drain valve (field supply)	FCU 1...n	Fan coil units (field supply)

NOTE

- The volume of balance tank(8) should be greater than 40L(for 5~9kW unit, greater than 20L). The drain valve (6) should be installed at the lowest position of the system. An independent backup heater can be selected and installed in the door. pump(10) and pump(23.1) should be controlled by outdoor unit and connect to corresponding port in the outdoor unit(refer to 9.7.6 Connection for other components/For outside circulation pump P_o and For tank loop pump P_d and mix pump P_c).
- The advantage of the dual set point control is that the heat pump will/can operate at the lowest required water flow temperature when only floor heating is required. Higher water flow temperatures are only required in case fan coil units are operating. This results in better heat pump performance.

• Pump operation and space heating

The pump (1.8) and (10) will operate when there is request for heating from A and/or B. Pump (23.1) will operate only when there is request for heating from B. The outdoor unit will start operating to achieve the target water flow temperature. The target water leaving temperature depends on which room thermostat is requesting heating. When the room temperature of both zones is above the thermostat set point, the outdoor unit and pump will stop operating.

NOTE

- Make sure to correctly configure the room thermostat installation on the user interface. Refer to "10.7 Field settings/ROOM THERMOSTAT".
- It is the installers' responsibility to ensure that no unwanted situations can occur (e.g. extremely high temperature water going towards floor heating loops, etc.)
- The supplier does not offer any type of mixing station. Dual set point control only provides the possibility to use two set points.
- When only zone A requests heating, zone B will be fed with water at a temperature equal to the first set point. This can lead to unwanted heating in zone B.
- When only zone B requests heating, the mixing station will be fed with water at a temperature equal to the second set point. Depending on the control of the mixing station, the floor heating loop can still receive water at a temperature equal to the set point of the mixing station.
- Be aware that the actual water temperature through the floor heating loops depends on the control and setting of the mixing station.

8.7 Application 7

Dual setpoint function application without room thermostat connect to the outdoor unit.

- Heating is provided through floor heating loops and fan coil units. The floor heating loops and fan coil units require different operating water temperatures.
- The floor heating loops require a lower water temperature in heating mode compared to fan coil units. To achieve these two set points, a mixing station is used to adapt the water temperature according to requirements of the floor heating loops. The fan coil units are directly connected to the unit water circuit and the floor heating loops are after the mixing station. Control of this mixing station is not done by the unit.
- The operation and configuration of the field water circuit is the responsibility of the installer.
- We only offer a dual set point control function. This function allows two set points to be generated. Depending on the required water temperature (floor heating loops and/or fan coil units are required) the first set point or second set point can be activated. See 10.7 field setting /TEMP. TYPE SETTING.

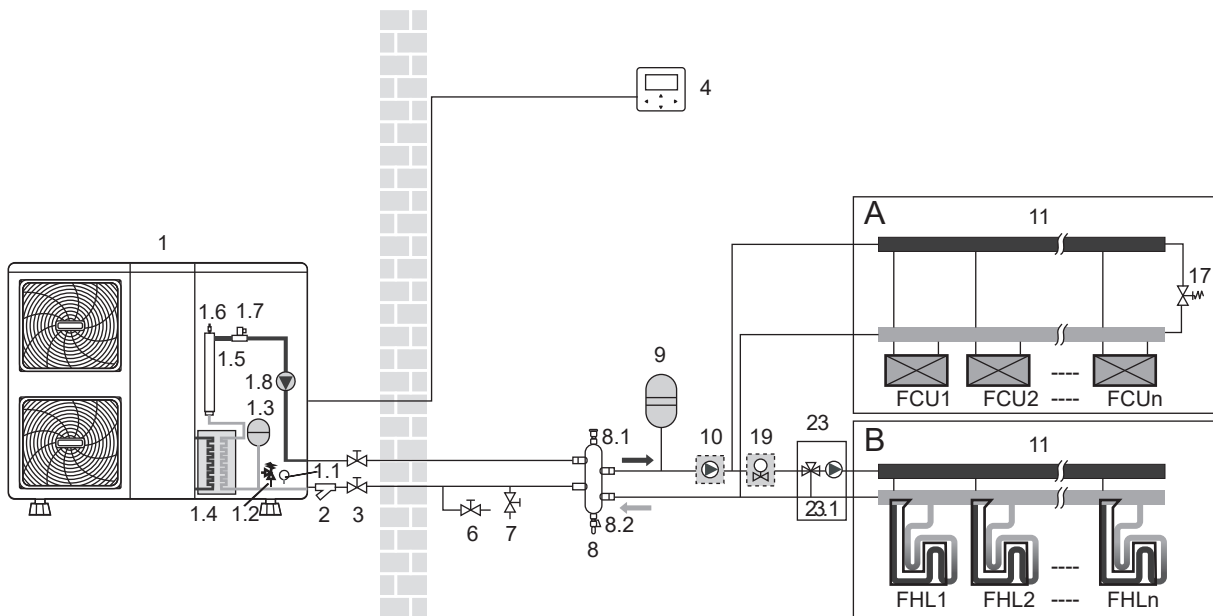

Coding	Assembly unit	Coding	Assembly unit
1	Outdoor unit	7	Fill valve (field supply)
1.1	Manometer	8	Balance tank (field supply)
1.2	Pressure relief valve	8.1	Air purge valve
1.3	Expansion vessel	8.2	Drain valve
1.4	Plate heat exchanger	9	Expansion vessel (field supply)
1.5	Backup heater (Customized model)	10	P_o: Outside circulation pump (field supply)
1.6	Air purge valve	11	Collector (field supply)
1.7	Flow switch	17	Bypass valve (field supply)
1.8	P_i: Circulate pump in the unit	19	SV2:2-way valve (field supply)
2	Y-shape filter	23	Mixing station (field supply)
3	Stop valve (field supply)	23.1	P_c: mixing pump
4	Wired controller	FHL 1...n	Floor heating loop (field supply)
6	Drain valve (field supply)	FCU 1...n	Fan coil units (field supply)

NOTE

- The volume of balance tank(8) should be greater than 40L(for 5~9kW unit, greater than 20L) The drain valve (6) should be installed at the lowest position of the system. An independent backup heater can be selected and installed in the door.
- As the temperature sensor attached in the user interface is used to detect the room temperature, the user interface (4) should be placed in the room where floor heating loops and fan coil units is installed and away from the heating source. Correct configuration should be applied in the user interface (refer to 10.7 field settings/TEMP. TYPE SETTING). The first setpoint is water temperature which can be set on the main page of user interface, the second setpoint is calculated from climate related curves, the target outlet water temperature is the higher one of these two setpoints. The unit will turn off when the room temperature reaches the target temperature.

• Pump operation and space heating

The pump (1.8) and (10) will operate when there is request for heating from A and/or B. Pump (23.1) will operate when the room temperature of zone B is lower than the set point which set in the user interface. The outdoor unit will start operating to achieve the target water flow temperature.

8.8 Application 8

Space heating application and domestic hot water heating with a solar energy kit connected to the system; space heating is provided by heat pump, domestic hot water heating is provided by heat pump and solar energy kit.

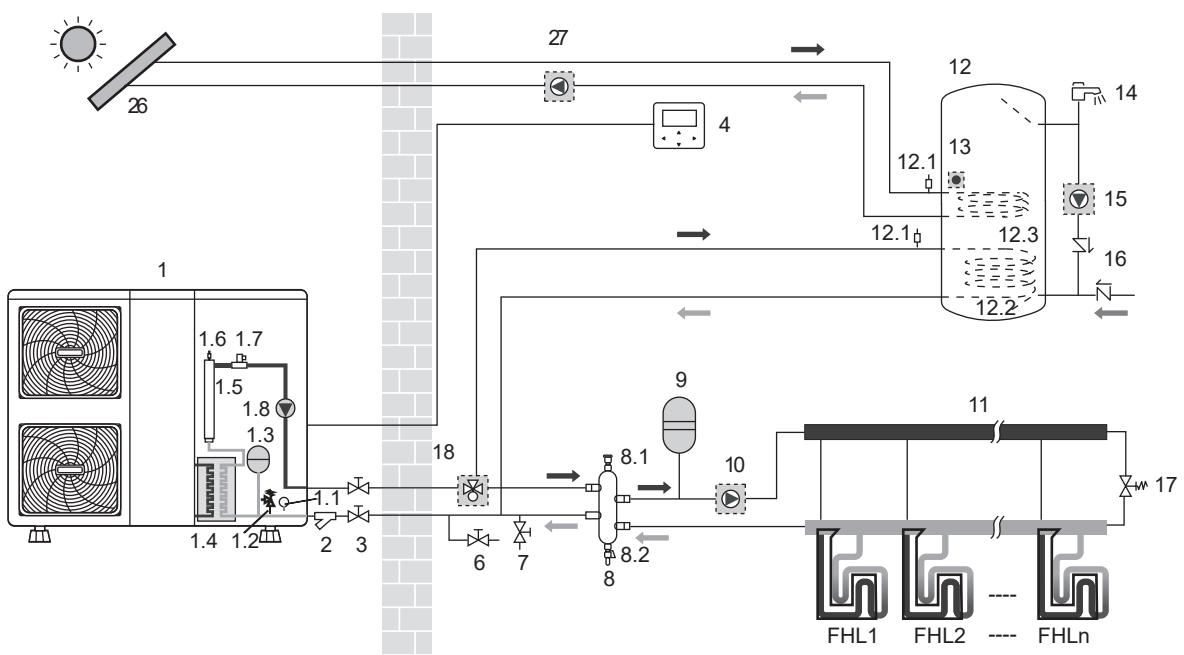

Coding	Assembly unit	Coding	Assembly unit
1	Outdoor unit	9	Expansion vessel (field supply)
1.1	Manometer	10	P_o: Outside circulation pump (field supply)
1.2	Pressure relief valve	11	Collector (field supply)
1.3	Expansion vessel	12	Domestic hot water tank (field supply)
1.4	Plate heat exchanger	12.1	Air purge valve
1.5	Backup heater (Customized model)	12.2	Heat exchanger coil
1.6	Air purge valve	12.3	Booster heater
1.7	Flow switch	13	T5: Temperature sensor
1.8	P_i: Circulate pump in the unit	14	Hot water tap (field supply)
2	Y-shape filter	15	P_d: DHW pump (field supply)
3	Stop valve (field supply)	16	One way valve (field supply)
4	Wired controller	17	Bypass valve(field supply)
6	Drain valve (field supply)	18	SV1: 3-way valve (field supply)
7	Fill valve (field supply)	FHL 1...n	Floor heating loop (field supply)
8	Balance tank (field supply)	26	Solar energy kit(field supply)
8.1	Air purge valve	27	P_s: Solar pump(field supply)
8.2	Drain valve	/	/

NOTE

The volume of balance tank(8) should be greater than 40L(for 5~9kW unit, greater than 20L) The drain valve (6) should be installed at the lowest position of the system. An independent backup heater can be selected and installed in the door.

The pump (1.8) and (10) will operate when there is a request for heating floor heating loops. The outdoor unit will start operating to achieve the target water flow temperature. The target water can be set in the wired controller.

If solar energy is set available in the wired controller(refer to 10.7 Field settings/OTHER HEATING SOURCE), the heating of domestic hot water can be done by either the solar energy kit or heat pump. when the solar energy kit turns on, signal will be sent to the outdoor unit, then the pump (27) will operate, the heat pump will stop heating for domestic hot water during solar energy kit operation .

NOTE

Make sure to wiring the solar energy kit(26) and solar pump(27) correctly, refer to "9.6.6 Connection for other components/For solar energy kit". User interface should be correctly configured, refer to "10.7 Field settings/OTHER HEATING SOURCE".

9 OVERVIEW OF THE UNIT

9.1 Disassembling the unit

Door 1 To access to the compressor and electrical parts and hydraulic compartment

Door 1 To access to the compressor and electrical parts.

Door 2 To access to the hydraulic compartment and electrical parts.

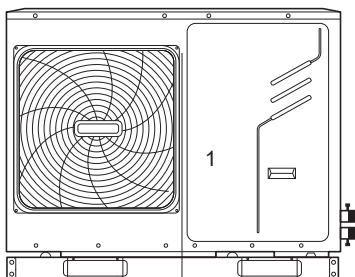

5/7/9kW

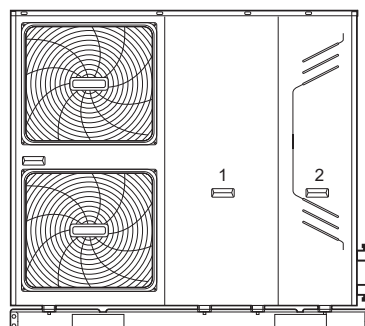

12/14/16kW

⚠ WARNING

- Switch off all power — i.e. unit power supply and backup heater and domestic hot water tank power supply (if applicable) — before removing doors 1 and 2.
- Parts inside the unit may be hot.

Push the grill to the left until it stops, then pull its right edge, so you can removed the grill. You can also reverse the procedure. Be careful to avoid hand injury.

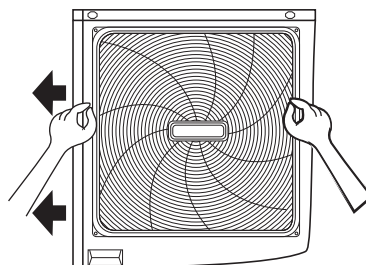
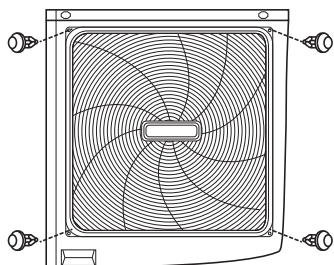

9.2 Main components

9.2.1 Hydraulic module

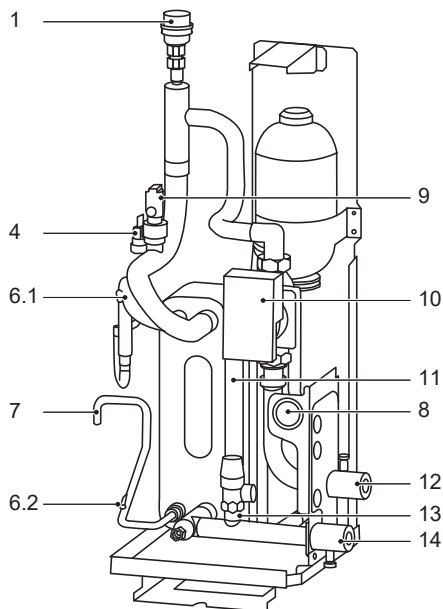

5/7/9kW

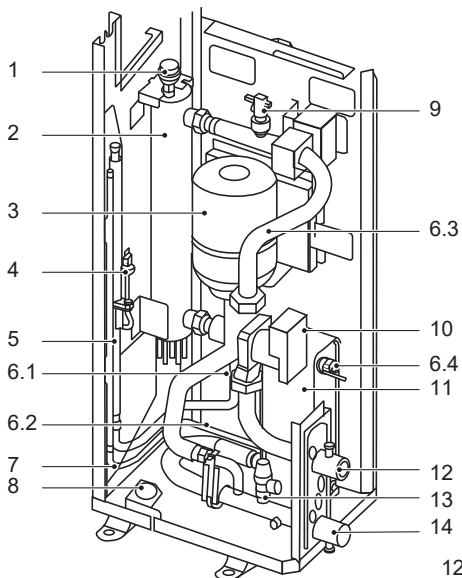
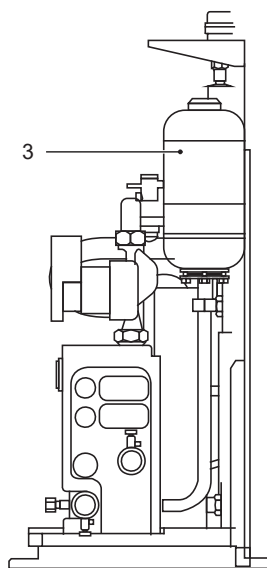

12/14/16kW

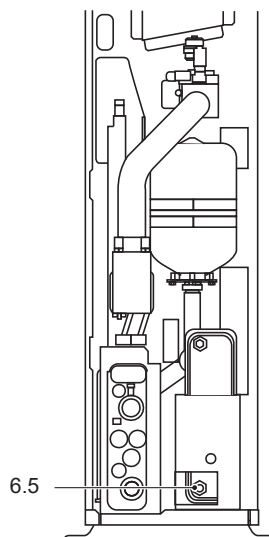

Coding	Assembly unit	Explanation
1	Air purge valve	Remaining air in the water circuit will be automatically removes air from the water circuit.
2	Backup heater(optional)	Provides additional heating capacity when the heating capacity of the heat pump is insufficient due to very low outdoor temperature. Also protects the external water piping from freezing.
3	Expansion vessel	Balances water system pressure. (Expansion vessel volume: 2L in 5/7/9kW units and 5L in 12/14/16kW units.)
4	Pressure Sensor	/
5	Refrigerant gas connection	/
6	Temperature sensors	Four temperature sensors determine the water and refrigerant temperature at various points in the water circuit. 6.1-T2B; 6.2-T2; 6.3-T1(optional); 6.4-TW_out; 6.5-TW_in
7	Refrigerant liquid connection	/
8	Manometer	Provides water circuit pressure readout.
9	Flow switch	Detects water flow rate to protect compressor and water pump in the event of insufficient water flow.
10	Pump	Circulates water in the water circuit.
11	Plate heat exchanger	Transfer heat from the refrigerant to the water.
12	Water outlet connection	/
13	Pressure relief valve	Prevents excessive water pressure by opening at 3 bar and discharging water from the water circuit.
14	Water inlet connection	/

9.2.2 Hydraulic system diagram

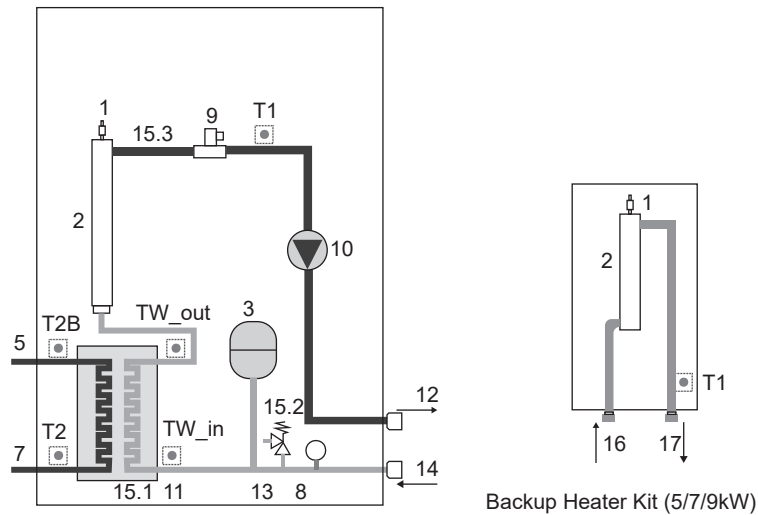

Coding	Assembly unit	Coding	Assembly unit
1	Air purge valve	12	Water outlet connection
2	Water vessel with backup heater(optional)	13	Pressure relief valve
3	Expansion vessel	14	Water inlet connection
5	Refrigerant gas connection	15.1	Electrical heating tape
7	Refrigerant liquid connection	15.2	Electrical heating tape
8	Manometer	15.3	Electrical heating tape
9	Flow switch	16	Water inlet connection
10	Circulation pump	17	Water outlet connection
11	Plate heat exchanger	Temperature sensors:TW_in;TW_out;T2B;T2;T1(optional)	

NOTE

- The standard unit is without backup heater. Backup heater kit is an optional part for 5,7,9kw models. Backup heater can be integrated in the unit for customized models(12,14,16kW).
- If the backup heater is installed, the port (CN6) for T1 in the main control board of hydraulic compartment should connect to the corresponding port in the backup heater kit.

9.3 Electronic control box

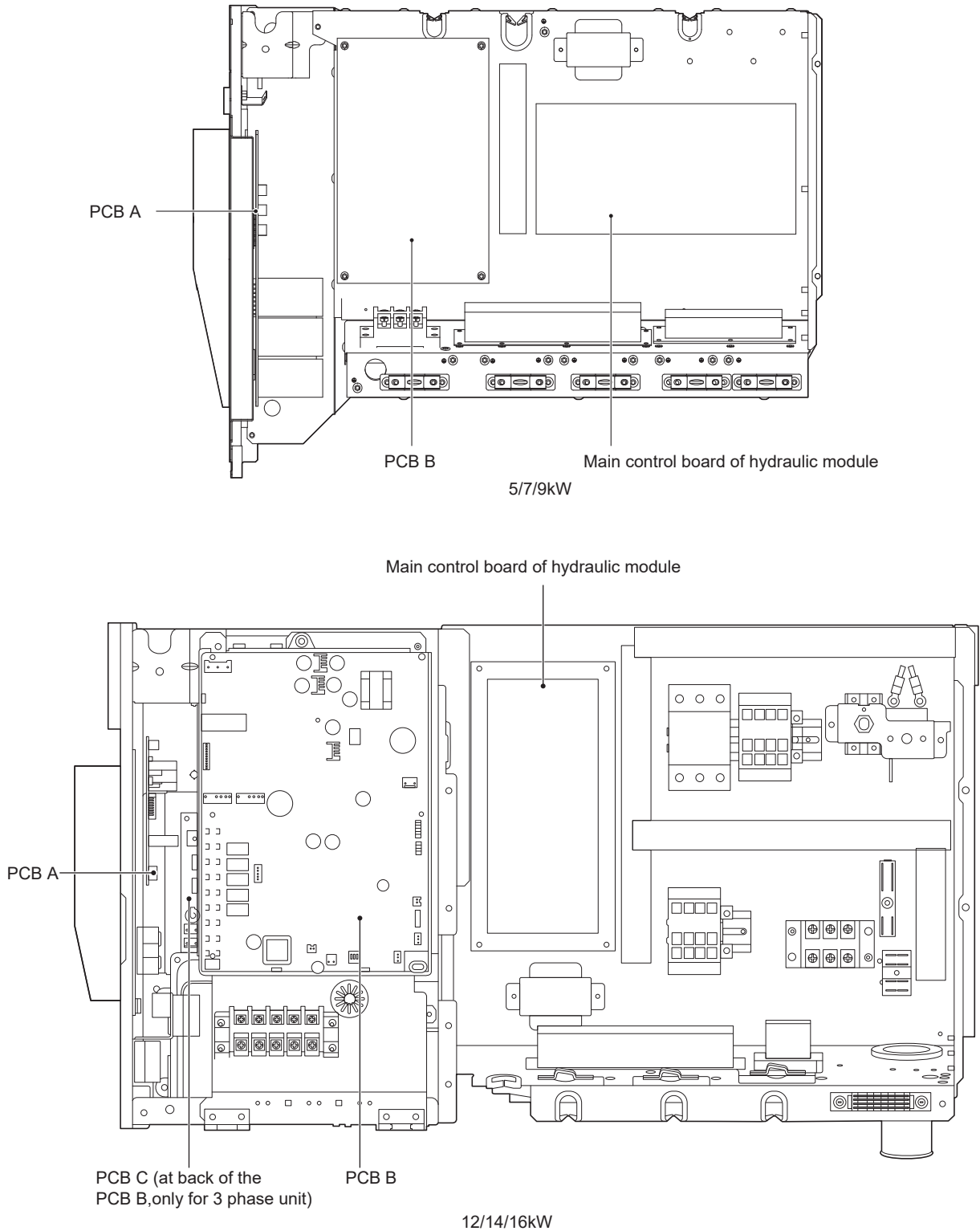

Note: The picture is for reference only, please refer to the actual product.

9.3.1 Main control board of hydraulic module

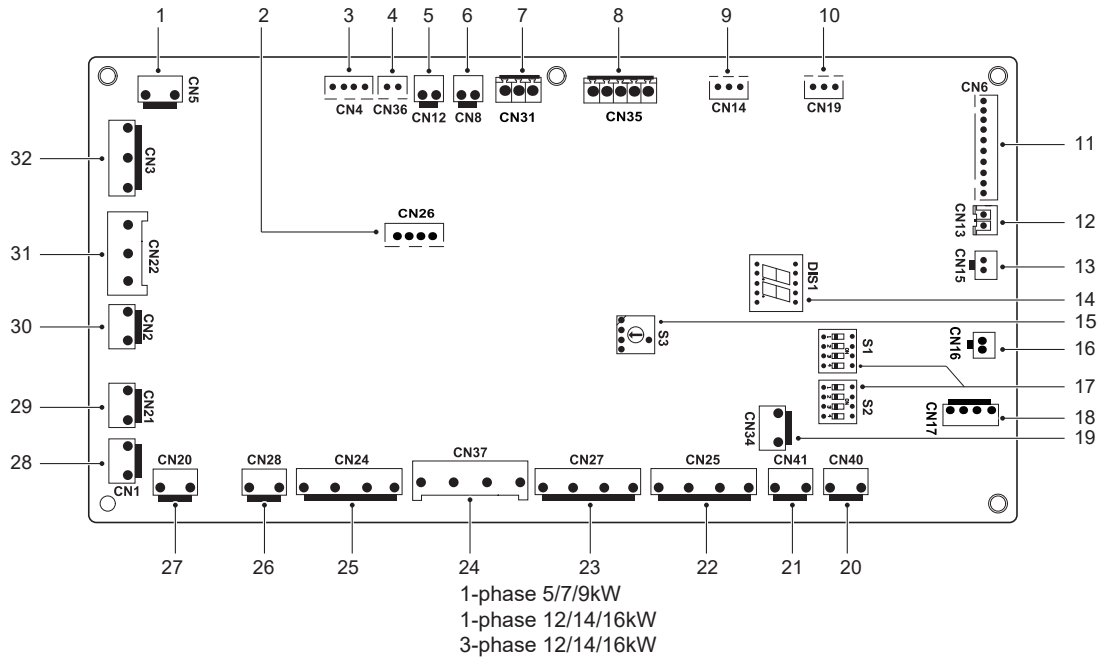

Coding	Assembly unit
1	Input port for solar kits(CN5)
2	Port for IC programming(CN26)
3	Output port for transformer(CN4)
4	Power supply port for the wired controller(CN36)
5	Port for remote switch(CN12)
6	Port for flow switch(CN8)
7	Control port for room thermostat (heating mode)(HT)/Control port for room thermostat (cooling mode)(CL)/Power port for room thermostat(COM)(CN31)
8	Port for smart grid (photovoltaic signal)(SG)/Port for smart grid (grid signal)(EVU)(CN35)
9	Port for communication with the wired controller(CN14)
10	Port for communication with PCB B(CN19)
11	Port for temp.sensors(TW_out, TW_in, T1, T2,T2B)(CN6)
12	Port for temp.sensor(T5, domestic hot water tank temp.sensor)(CN13)
13	Port for temp.sensor(T1B, the final outlet temp.sensor)(CN15)
14	Digital display(DIS1)
15	Rotary dip switch(S3)
16	Port for temperature sensor of room temperature(CN16)
17	Dip switch(S1,S2)
18	Port for internal pump(CN17)
19	Output port for deforst(CN34)
20	Port for anti-freeze electric heating tape (internal)(CN40)
21	Port for anti-freeze electric heating tape (internal)(CN41)
22	Output port for external heating source /Output for operation(CN25)
23	Port for anti-freeze electric heating tape(HEAT) /solar energy pump(P_S)/remote alarm(ALARM)(CN27)
24	Port for external circulted pump (P_o) /pipe pump(P_d)/mix pump(P_c)/2-way valve(SV2)(CN37)
25	Port for SV1(3-way valve) and SV3(CN24)
26	Port for internal pump(CN28)
27	Input port for transformer(CN20)
28	Feedback port for temperature switch(CN1)
29	Port for power supply(CN21)
30	Feedback port for external temp. switch(shorted in default)(CN2)
31	Control port for backup heater/booster heater(CN22)
32	Control port for room thermostat(CN3)

9.3.2 1-phase for 5/7/9kW units

1) PCB A, Inverter module

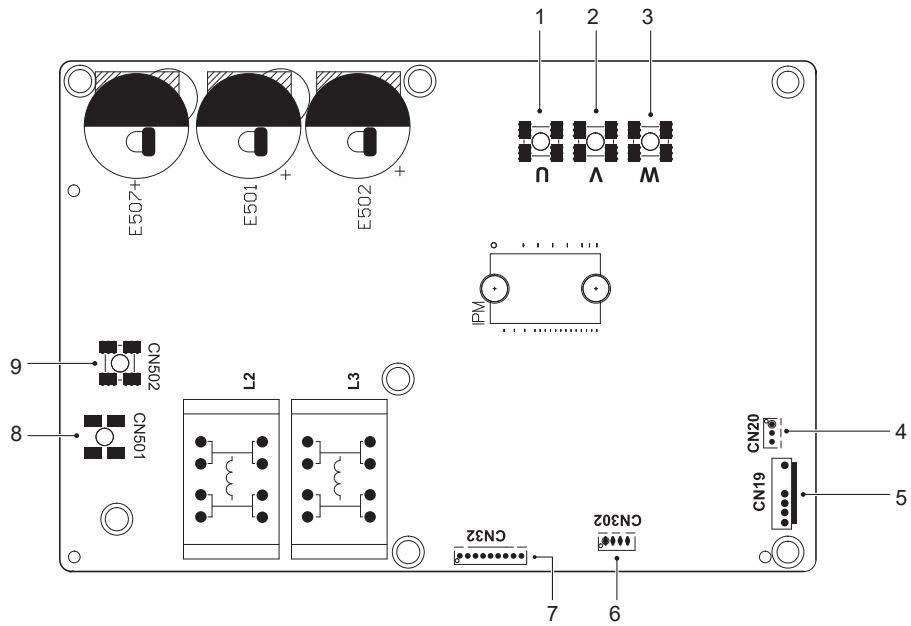

Coding	Assembly unit	Coding	Assembly unit
1	Compressor connection port U	6	Reserved(CN302)
2	Compressor connection port V	7	Port for communication with PCB B(CN32)
3	Compressor connection port W	8	Input port L for rectifier bridge(CN501)
4	Output port for +12V/5V(CN20)	9	Input port N for rectifier bridge(CN502)
5	Port for fan(CN19)	/	/

2) PCB B, Main control board

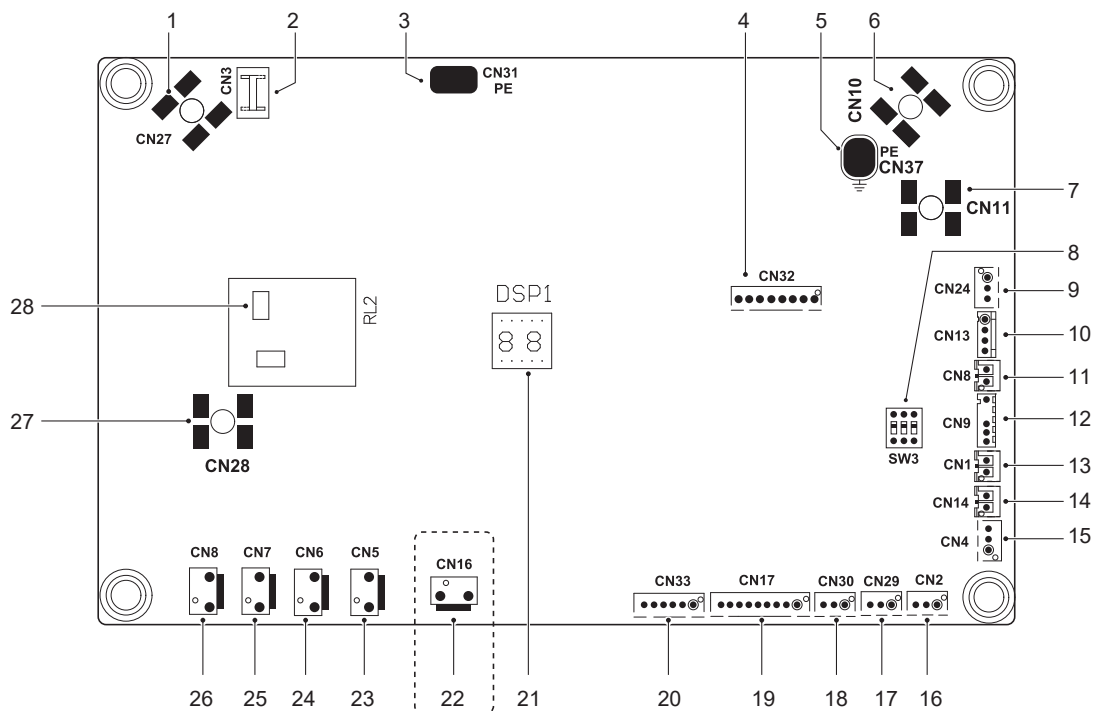

Coding	Assembly unit	Coding	Assembly unit
1	Output port N to PCB A(CN27)	15	Port for pressure sensor(CN4)
2	Output port N to hydro-box control board(CN3)	16	Reserved(CN2)
3	Port for ground wire(CN31)	17	Port for communication with hydro-box control board (CN29)
4	Port for IC programming(CN32)	18	Reserved(CN30)
5	Port for ground wire(CN37)	19	Port for communication with PCB A(CN17)
6	Input port for neutral wire(CN10)	20	Port for electrical expansion valve(CN33)
7	Input port for live wire(CN11)	21	Digital display(DSP1)
8	DIP switch(SW3)	22	Port for chassis electrical heating tape(CN16)(optional)
9	Input port for +12V/5V(CN24)	23	Port for SV6 valve(CN5)
10	Port for low pressure switch and high pressure switch(CN13)	24	Port for 4-way valve(CN6)
11	Port for discharge temp.sensor(CN8)	25	Port for compressor electric heating tape 1(CN7)
12	Port for outdoor ambient temp. sensor and condenser temp.sensor(CN9)	26	Port for compressor electric heating tape 2(CN8)
13	Port for suction temp.sensor(CN1)	27	Output port L to PCB A(CN28)
14	Port for TF temp.sensor(CN14)	28	Output port L to hydro-box control board(RL2)

9.3.3 1-phase for 12/14/16 kW units

1) PCB A, Inverter module

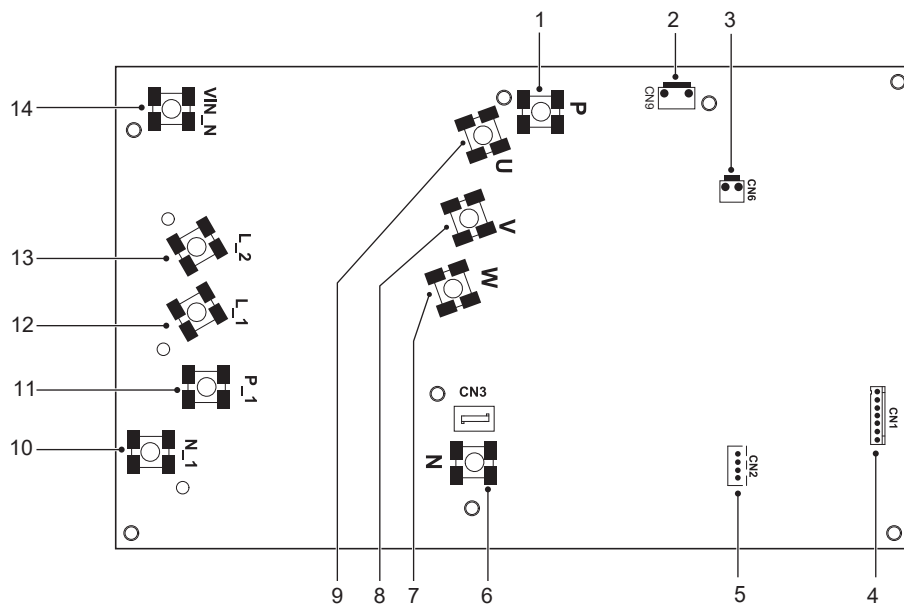

Coding	Assembly unit	Coding	Assembly unit
1	Input port P for IPM module(P)	8	Compressor connection port V
2	Input port for high pressure switch(CN9)	9	Compressor connection port U
3	Output port for +15V(CN6)	10	Output port N for PFC module(N_1)
4	Port for communication with PCB B(CN1)	11	Output port P for PFC module(P_1)
5	Reserved(CN2)	12	Input port for PFC inductance L_1(L_1)
6	Input port N for IPM module(N)	13	Input port for PFC inductance L_2(L_2)
7	Compressor connection port W	14	Input port N for PFC module(VIN_N)

2) PCB B, Main control board

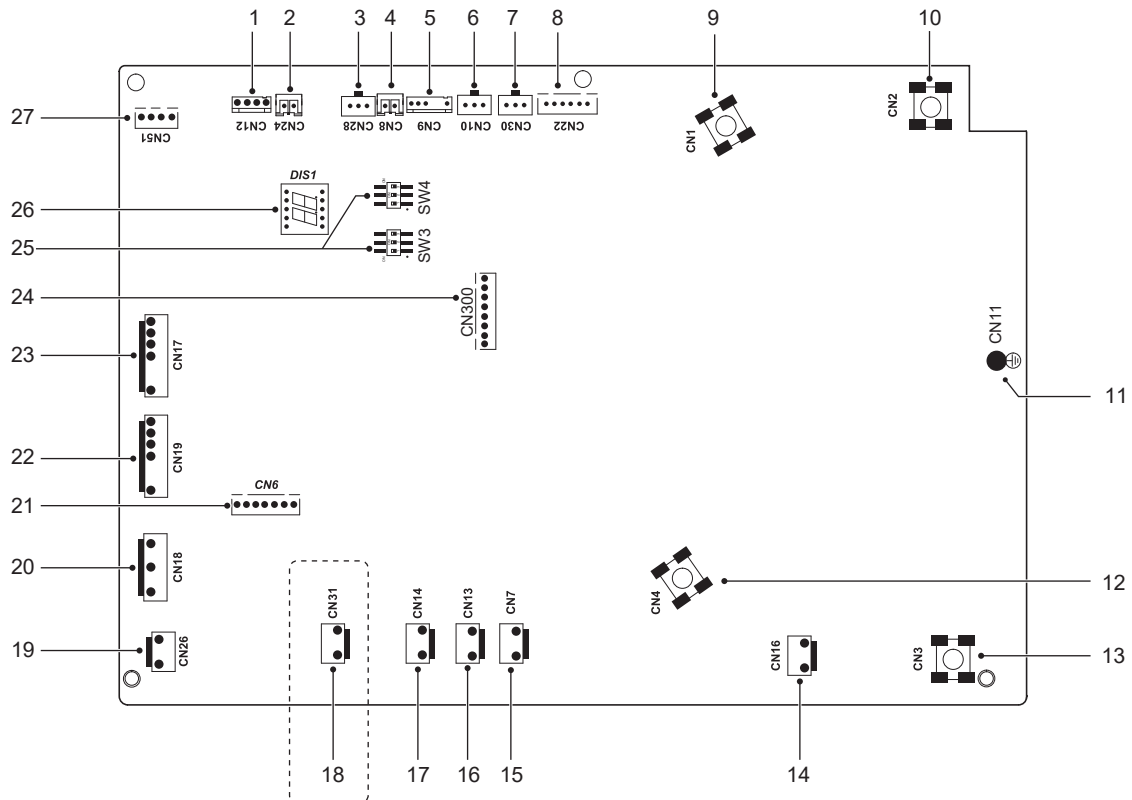

Coding	Assembly unit	Coding	Assembly unit
1	Port for low pressure switch and quick check(CN12)	14	Power supply port for hydro-box control board(CN16)
2	Port for suction temp.sensor(CN24)	15	Port for SV6 value(CN7)
3	Port for pressure sensor(CN28)	16	Port for 4-way value(CN13)
4	Port for discharge temp.sensor(CN8)	17	Port for compressor electrical heating tape(CN14)
5	Port for outdoor ambient temp. sensor and condenser temp. sensor(CN9)	18	Port for chassis electrical heating tape(CN31) (Optional)
6	Port for communication with hydro-box control board (CN10)	19	Input port for transformer(CN26)
7	Reserved(CN30)	20	Power supply port for fan(CN18)
8	Port for electrical expansion valve(CN22)	21	Port for communication with PCB A(CN6)
9	Input port for live wire(CN1)	22	Port for down fan(CN19)
10	Input port for neutral wire(CN2)	23	Port for up fan(CN17)
11	Ground wire(CN11)	24	Port for IC programming(CN300)
12	Ourput port for live wire(CN4)	25	DIP switch(SW3,SW4)
13	Output port for neutral wire(CN3)	26	Digital display(DIS1)
		27	Output port for transformer(CN51)

9.3.4 3-phase for 12/14/16 kW units

1) PCB A, Inverter module

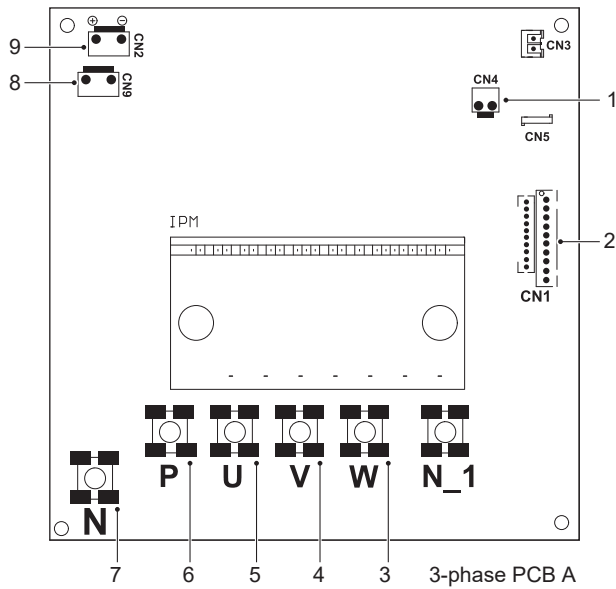

Coding	Assembly unit
1	Output port for +15V(CN4)
2	Port for communication with PCB B (CN1)
3	Compressor connection port W
4	Compressor connection port V
5	Compressor connection port U
6	Input port P for IPM module(P)
7	Input port N for IPM module(N)
8	Input port for high pressure switch (CN9)
9	Power for switching power supply(CN2)

2) PCB B, Main control board

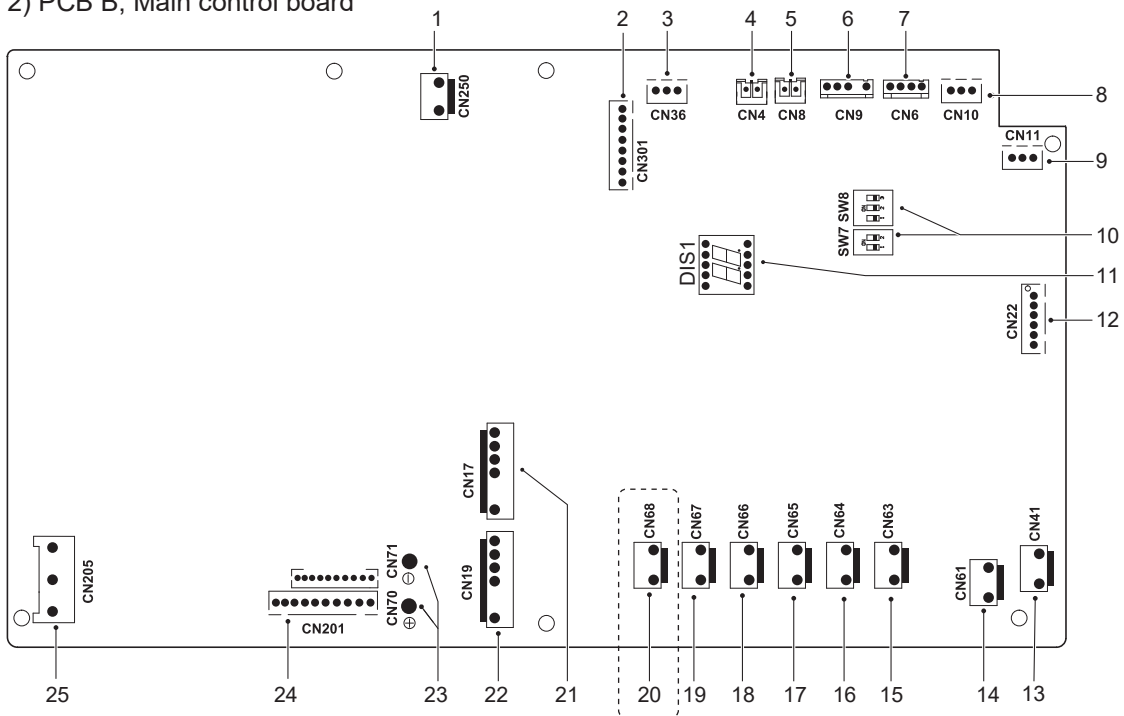

Coding	Assembly unit	Coding	Assembly unit
1	Power supply port for PCB B(CN250)	14	Power supply port for hydro-box control board(CN61)
2	Port for IC programming(CN301)	15	Out port for PFC contactor coil(CN63)
3	Port for pressure sensor(CN36)	16	Out port for P_line contactor coil(CN64)
4	Port for suction temp.sensor(CN4)	17	Port for 4-way valve(CN65)
5	Port for discharge temp.sensor(CN8)	18	Port for electric heating tape(CN66)
6	Port for outdoor ambient temp. sensor and condenser temp.sensor(CN9)	19	PTC control(CN67)
7	Port for low pressure switch and quick check(CN6)	20	Port for chassis electrical heating tape(CN68)(optional)
8	Port for communication with hydro-box control board (CN10)	21	Port for up fan(CN17)
9	Reserved(CN11)	22	Port for down fan(CN19)
10	DIP switch(SW7,SW8)	23	Power supply port for module(CN70/71)
11	Digital display(DIS1)	24	Port for communication with PCB A(CN201)
12	Port for electrical expansion valve(CN22)	25	Port for voltage check(CN205)
13	Port for power supply(CN41)	/	/

3) PCB C, filter board

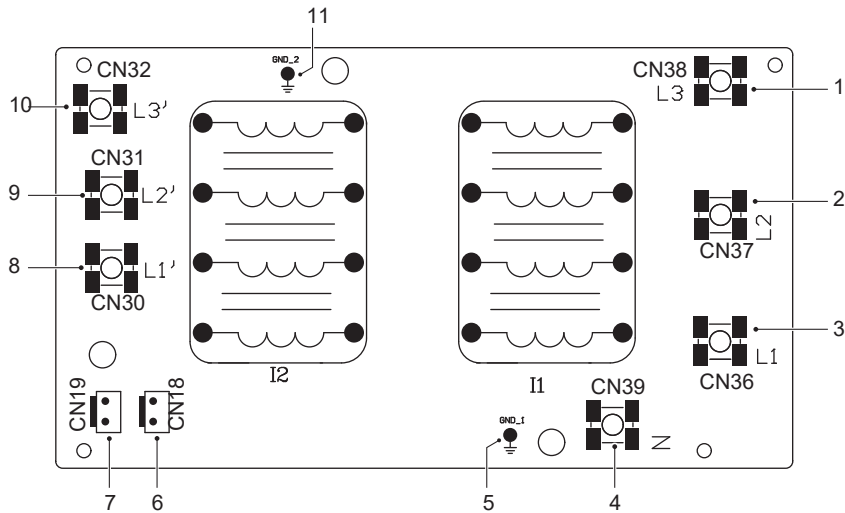

PCB C 3-phase 12/14/16kW

Coding	Assembly unit	Coding	Assembly unit
1	Power supply L3(L3)	7	Power supply port for main control board(CN19)
2	Power supply L2(L2)	8	Power filtering L1(L1')
3	Power supply L1(L1)	9	Power filtering L2(L2')
4	Power supply N(N)	10	Power filtering L3(L3')
5	Ground wire(GND_1)	11	Ground wire(GND_2)
6	Power supply port for load(CN18)	/	/

9.3.5 Controls parts for backup heater(Reserved)

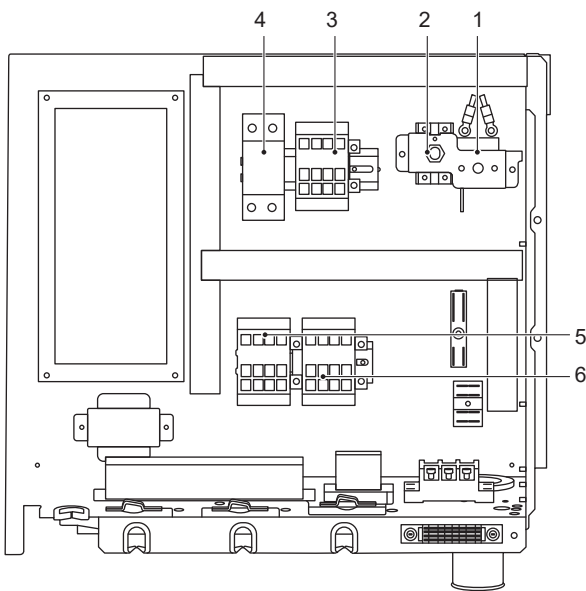

1-phase 12/14/16kW

Coding	Assembly unit
1	Auto thermal protector
2	Manu thermal protector
3	Backup heater contactor KM4
4	Backup heater circuit breaker CB
5	Backup heater contactor KM1
6	Backup heater contactor KM2

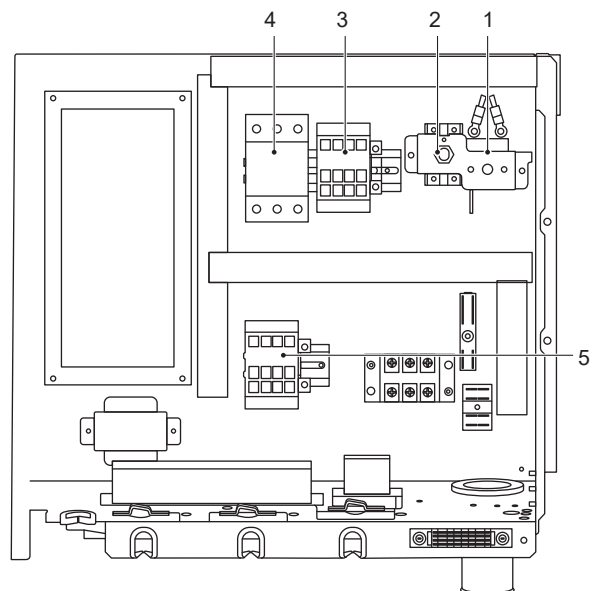

3-phase 12/14/16kW

Coding	Assembly unit
1	Auto thermal protector
2	Manu thermal protector
3	Backup heater contactor KM4
4	Backup heater circuit breaker CB
5	Backup heater contactor KM1

9.4 Water piping

All piping lengths and distances have been taken into consideration.

Requirements	Valve
The maximum allowed thermistor cable length is 20m. This is the maximum allowable distance between the domestic hot water tank and the unit (only for installations with a domestic hot water tank). The thermistor cable supplied with the domestic hot water tank is 10m in length. In order to optimize efficiency we recommend installing the 3-way valve and the domestic hot water tank as close as possible to the unit.	Thermistor cable length minus 2m

NOTE

If the installation is equipped with a domestic hot water tank (field supply), please refer to the domestic hot water tank Installation And Owner's Manual. If there is no glycol (anti-freeze) in the system there is a power supply or pump failure, drain the system (as shown in the figure below).

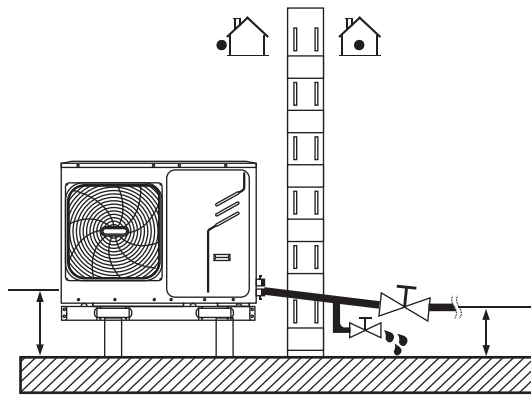

NOTE

If water is not removed from the system in freezing weather when unit is not used. The frozen water may damage the water circle parts.

9.4.1 Check the water circuit

The units are equipped with a water inlet and outlet for connection to a water circuit.

The units should only be connected to closed water circuits. Connection to an open water circuit would lead to excessive corrosion of the water piping. Only materials complying with all applicable legislation should be used.

Example:

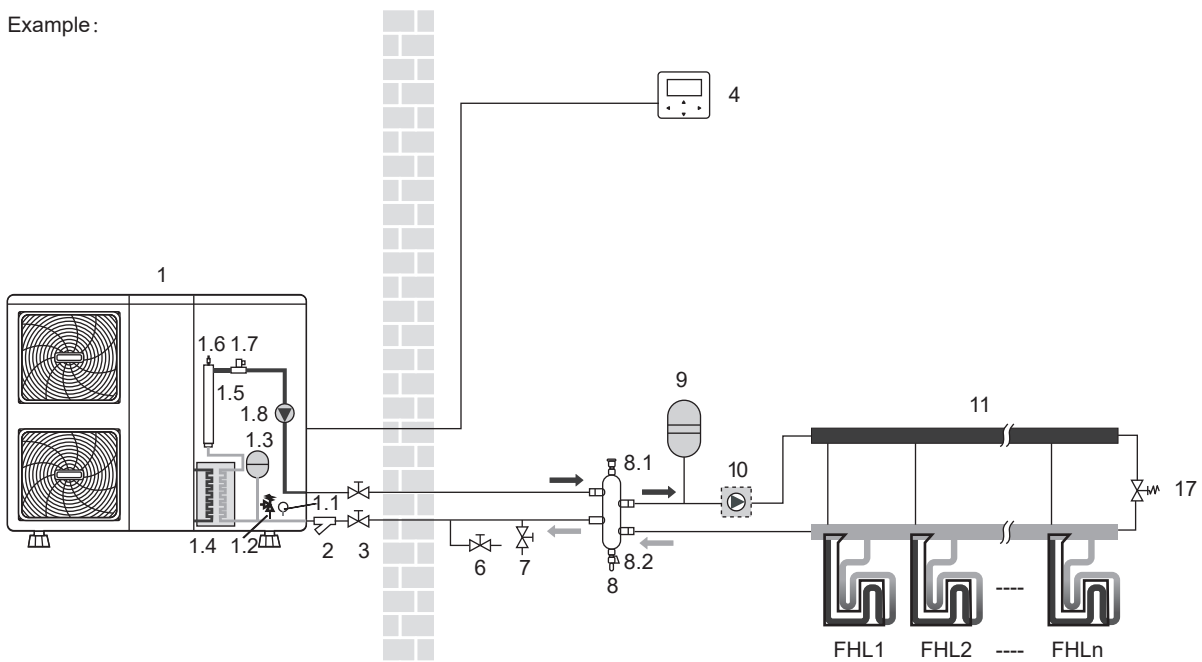

Before continuing installation of the unit, check the following:

- The maximum water pressure ≤ 3 bar.
- The maximum water temperature $\leq 70^{\circ}\text{C}$ according to safety device setting.
- Always use materials that are compatible with the water used in the system and with the materials used in the unit.
- Ensure that components installed in the field piping can withstand the water pressure and temperature.
- Drain taps must be provided at all low points of the system to permit complete drainage of the circuit during maintenance.
- Air vents must be provided at all high points of the system. The vents should be located at points that are easily accessible for service. An automatic air purge is provided inside the unit. Check that this air purge valve is not tightened so that automatic release of air in the water circuit is possible.

9.4.2 Water volume and expansion vessel pre-pressure checks

The units are equipped with an expansion vessel (5/7/9kW models:2L; 12/14/16kW models:5L) that has a default pre-pressure of 1.5 bar. To assure proper operation of the unit, the pre-pressure of the expansion vessel might need to be adjusted.

1) Check that the total water volume in the installation, excluding the internal water volume of the unit, is at least 25L(for 5/7/9 kW unit, the minimum volume is 15L) . Refer to 14 Technical specifications to find the total internal water volume of the unit.

NOTE

- In most applications this minimum water volume will be satisfactory.
- In critical processes or in rooms with a high heat load though, extra water might be required.
- When circulation in each space heating loop is controlled by remotely controlled valves, it is important that this minimum water volume is kept even if all the valves are closed.

2) Using the table below, determine if the expansion vessel pre- pressure requires adjustment.

3) Using the table and instructions below, determine if the total water volume in the installation is below the maximum allowed water volume.

Installation height difference(a)	Water volume ≤ 72 L(b)	Water volume >72 L(b)
≤ 12 m	No pre-pressureread justment required.	<p>Actions required:</p> <ul style="list-style-type: none"> • Pre-pressure must be increased, calculate according to "Calculating the pre-pressure of the expansion vessel" below. • Check if the water volume is lower than maximum allowed water volume (use graph below)
>12 m	<p>Actions required:</p> <ul style="list-style-type: none"> • Pre-pressure must be increased, calculate according to "Calculating the pre-pressure of the expansion vessel" below. • Check if the water volume is lower than maximum allowed water volume (use graph below) 	Expansion vessel of the unit too small for the installation.

- Heighe difference is between the highest point of the water circuit and the outdoor unit's expansion tank. Unless the unit is located at the highest point of the system, in which case the installation height difference is considered to be zero.
- For 1-phase 12~16kW and 3-phase 12~16kW units, this value is 72L, for 5~9kW units, this value is 30 L.

Calculating the pre-pressure of the expansion vessel

The pre-pressure (P_g) to be set depends on the maximum installation height difference (H) and is calculated as follows:
 $P_g(\text{bar}) = (H(\text{m})/10 + 0.3)$ bar

Checking the maximum allowed water volume

To determine the maximum allowed water volume in the entire circuit, proceed as follows:

- Determine the calculated pre-pressure (Pg) for the corresponding maximum water volume using the graph below.
- Check that the total water volume in the entire water circuit is lower than this value. If this is not the case, the expansion vessel inside the unit is too small for the installation.

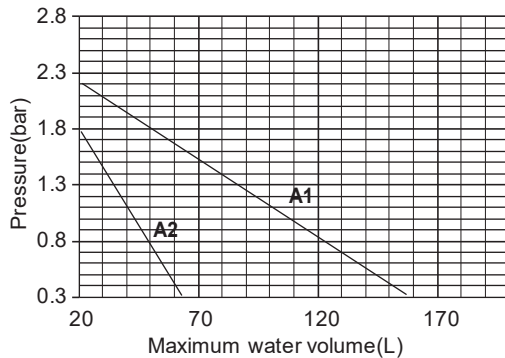

Pre-pressure = pre-pressure of the expansion vessel
 Maximum water volume = maximum water volume in the system

A1 System without glycol for 1-phase 12~16 kW and 3-phase 12~16 kW unit

A2 System without glycol for the 5/7/9 kW unit

Example 1 :

The unit(16kW) is installed 10m below the highest point in the water circuit. The total water volume in the water circuit is 50 L. In this example, no action or adjustment is required.

Example 2 :

The unit(16kW) is installed at the highest point in the water circuit. The total water volume in the water circuit is 150 L.

Result:

- Since 150 L is more than 72 L, the pre-pressure must be decreased (see table above).
- The required pre-pressure is: $P_g(\text{bar}) = (H(\text{m})/10+0.3) \text{ bar} = (0/10+0.3) \text{ bar} = 0.3 \text{ bar}$
- The corresponding maximum water volume can be read from the graph: approximately 160 L.

Since the total water volume (150 L) is below the maximum water volume (160 L), the expansion vessel suffices for the installation.

Setting the pre-pressure of the expansion vessel

When it is required to change the default pre-pressure of the expansion vessel (1.5 bar), following guidelines:

- Use only dry nitrogen to set the expansion vessel pre-pressure.
- Inappropriate setting of the expansion vessel pre-pressure will lead to malfunctioning of the system. Pre-pressure should only be adjusted by a licensed installer.

Selecting the additional expansion vessel

If the expansion vessel of the unit is too small for the installation, an additional expansion vessel is needed.

- calculate the pre-pressure of the expansion vessel: $P_g(\text{bar})=(H(\text{m})/10+0.3) \text{ bar}$
the expansion vessel equipped in the unit should adjust the pre- pressure also.
- calculate the volume needed of the additional expansion vessel:
 $V1=0.0693 \cdot V_{\text{water}} / (2.5-P_g) - V_0$
 V_{water} is volume of water in the system, V_0 is volume of expansion vessel which the unit is equipped(10~16kW, $V_0=5\text{L}$, 5~9kW, $V_0=2\text{L}$).

9.4.3 Water circuit connection

Water connections must be made correctly in accordance with labels on the outdoor unit, with respect to the water inlet and water outlet.

CAUTION

Be careful not to deform the unit's piping by using excessive force when connecting the piping. Deforming the piping can cause the unit to malfunction.

If air, moisture or dust gets in the water circuit, problems may occur. Therefore, always take into account the following when connecting the water circuit:

- Use clean pipes only.
- Hold the pipe end downwards when removing burrs.
- Cover the pipe end when inserting it through a wall to prevent dust and dirt entering.
- Use a good thread sealant for sealing the connections. The sealing must be able to withstand the pressures and temperatures of the system.
- When using non-copper metallic piping, be sure to insulate two kind of materials from each other to prevent galvanic corrosion.
- For copper is a soft material, use appropriate tools for connecting the water circuit. Inappropriate tools will cause damage to the pipes.

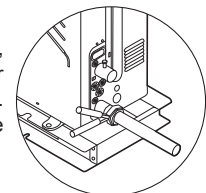

NOTE

The unit is only to be used in a closed water system. Application in an open water circuit can lead to excessive corrosion of the water piping:

- Never use Zn-coated parts in the water circuit. Excessive corrosion of these parts may occur as copper piping is used in the unit's internal water circuit.
- When using a 3-way valve in the water circuit. Preferably choose a ball type 3-way valve to guarantee full separation between the domestic hot water and floor heating water circuit.
- When using a 3-way valve or a 2-way valve in the water circuit. The recommended maximum changeover time of the valve should be less than 60 seconds.

9.4.4 Water circuit anti-freeze protection

Ice formation can cause damage to the hydraulic system. As the outdoor unit may be exposed to sub-zero temperatures, care must be taken to prevent freezing of the system.

All internal hydronic parts are insulated to reduce heat loss. Insulation must also be added to the field piping.

- The software contains special functions using the heat pump to protect the entire system against freezing. When the temperature of the water flow in the system drops to a certain value, the unit will heat the water, either using the heat pump, the electric heating tap, or the backup heater. The freeze protection function will turn off only when the temperature increases to a certain value.

In event of a power failure, the above features would not protect the unit from freezing.

Since a power failure could happen when the unit is unattended, the supplier recommends use anti-freeze fluid to the water system. Refer to "Caution: Use of glycol" .

Depending on the expected lowest outdoor temperature, make sure the water system is filled with a concentration of glycol as mentioned in the table below.

When glycol is added to the system, the performance of the unit will be affected. The correction factor of the unit capacity, flow rate and pressure drop of the system is listed in the table below.

Ethylene Glycol

Quality of glycol/%	Modification coefficient				Freezing point/°C
	Cooling capacity modification	Power modification	Water resistance	Water flow modification	
0	1.000	1.000	1.000	1.000	0.000
10	0.984	0.998	1.118	1.019	-4.000
20	0.973	0.995	1.268	1.051	-9.000
30	0.965	0.992	1.482	1.092	-16.000
40	0.960	0.989	1.791	1.145	-23.000
50	0.950	0.983	2.100	1.200	-37.000

Propylene Glycol

Quality of glycol/%	Modification coefficient				Freezing point/°C
	Cooling capacity modification	Power modification	Water resistance	Water flow modification	
0	1.000	1.000	1.000	1.000	0.000
10	0.976	0.996	1.071	1.000	-3.000
20	0.961	0.992	1.189	1.016	-7.000
30	0.948	0.988	1.380	1.034	-13.000
40	0.938	0.984	1.728	1.078	-22.000
50	0.925	0.975	2.150	1.125	-35.000

If no glycol is added, the water must be drained out when there is a power failure.

Water may enter into the flow switch and cannot be drained out and may freeze when the temperature is low enough. The flow switch should be removed and dried, then can be reinstalled in the unit.

WARNING

Ethylene Glycol and Propylene Glycol are TOXIC

The concentrations mentioned in the table above will not prevent freezing, but will prevent the hydraulics from bursting.

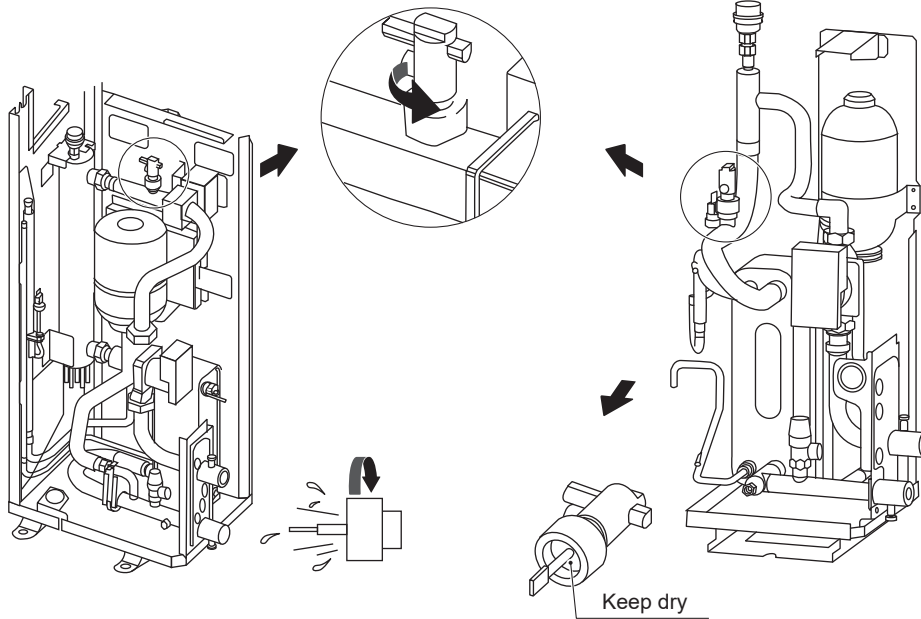

NOTE

Counterclockwise rotation, remove the flow switch.

Drying the flow switch completely.

CAUTION

Use of glycol

- Glycol use for installations with a domestic hot water tank: Only propylene glycol having a toxicity rating or class of 1, as listed in "Clinical Toxicology of Commercial Products, 5th edition" may be used. The maximum allowed water volume is then reduced according to the figure on page 36.
- If there is too much pressure when using glycol, connect the safety valve to a drain pan to recover the glycol.

Corrosion in the system due to glycol

Uninhibited glycol will turn acidic under the influence of oxygen. This process is accelerated by presence of copper and at higher temperatures. The acidic uninhibited glycol attacks metal surfaces and forms galvanic corrosion cells that cause severe damage to the system. It is of extreme importance:

- That the water treatment is correctly executed by a qualified water specialist.
- That a glycol with corrosion inhibitors is selected to counteract acids formed by the oxidation of glycols.
- That in case of an installation with a domestic hot water tank, only the use of propylene glycol is allowed. In other installations the use of ethylene glycol is fine.
- That no automotive glycol is used because their corrosion inhibitors have a limited lifetime and contain silicates that can foul or plug the system.
- That galvanized piping is not used in glycol systems since it may lead to the precipitation of certain elements in the glycol's corrosion inhibitor.
- To ensure that the glycol is compatible with the materials used in the system.

NOTE

- Be aware of the hygroscopic property of glycol. It absorbs moisture from the environment.
- Leaving the cap off the glycol container causes the concentration of water to increase. The glycol concentration is then lower and the water could freeze.
- Preventive actions must be taken to ensure minimal exposure of the glycol to air.

Also refer to "10.3 Pre-operation checks/Checks before initial start-up".

9.5 Adding water

- Connect the water supply to the fill valve and open the valve.
- Make sure the automatic air purge valve is open (at least 2 turns).
- Fill with water until the manometer indicates a pressure of approximately 2.0 bar. Remove air in the circuit as much as possible using the air purge valves. Air in the water circuit could lead to malfunction of the backup electric heater.

Do not fasten the black plastic cover on the vent valve at the top side of the unit when the system is running. Open air purge valve, turn anticlockwise at least 2 full turns to release air from the system.

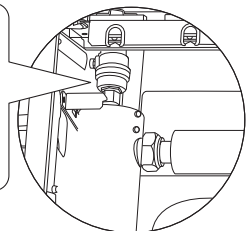

NOTE

During filling, it might not be possible to remove all air in the system. Remaining air will be removed through the automatic air purge valves during the first operating hours of the system. Topping up the water afterwards might be required.

- The water pressure indicated on the manometer will vary depending on the water temperature (higher pressure at higher water temperature). However, at all times water pressure should remain above 0.3 bar to avoid air entering the circuit.
- The unit might drain-off too much water through the pressure relief valve.
- Water quality should be complied with EN 98/83 EC Directives.

Detailed water quality condition can be found in EN 98/83 EC Directives.

9.6 Water piping insulation

The complete water circuit including all piping, water piping must be insulated to prevent condensation during cooling operation and reduction of the heating and cooling capacity as well as prevention of freezing of the outside water piping during winter. The insulation material should at least of B1 fire resistance rating and complies with all applicable legislation. The thickness of the sealing materials must be at least 13 mm with thermal conductivity 0.039 W/mK in order to prevent freezing on the outside water piping.

If the outdoor ambient temperature is higher than 30°C and the humidity is higher than RH 80%, then the thickness of the sealing materials should be at least 20 mm in order to avoid condensation on the surface of the seal.

9.7 Field wiring

WARNING

A main switch or other means of disconnection, having a contact separation in all poles, must be incorporated in the fixed wiring in accordance with relevant local laws and regulations. Switch off the power supply before making any connections. Use only copper wires. Never squeeze bundled cables and make sure they do not come in contact with the piping and sharp edges. Make sure no external pressure is applied to the terminal connections. All field wiring and components must be installed by a licensed electrician and must comply with relevant local laws and regulations.

The field wiring must be carried out in accordance with the wiring diagram supplied with the unit and the instructions given below.

Be sure to use a dedicated power supply. Never use a power supply shared by another appliance.

Be sure to establish a ground. Do not ground the unit to a utility pipe, surge protector, or telephone ground. Incomplete grounding may cause electrical shock.

Be sure to install a ground fault circuit interrupter (30 mA). Failure to do so may cause electrical shock.

Be sure to install the required fuses or circuit breakers.

9.7.1 Precautions on electrical wiring work

- Fix cables so that cables do not make contact with the pipes (especially on the high pressure side).
- Secure the electrical wiring with cable ties as shown in figure so that it does not come in contact with the piping, particularly on the high-pressure side.
- Make sure no external pressure is applied to the terminal connectors.
- When installing the ground fault circuit interrupter make sure that it is compatible with the inverter (resistant to high frequency electrical noise) to avoid unnecessary opening of the ground fault circuit interrupter.

NOTE

The ground fault circuit interrupter must be a high- speed type breaker of 30 mA (<0.1 s).

- This unit is equipped with an inverter. Installing a phase advancing capacitor not only will reduce the power factor improvement effect, but also may cause abnormal heating of the capacitor due to high-frequency waves. Never install a phase advancing capacitor as it could lead to an accident.

9.7.2 Wiring overview

The illustration below gives an overview of the required field wiring between several parts of the installation. Refer also to "8 Typical application examples".

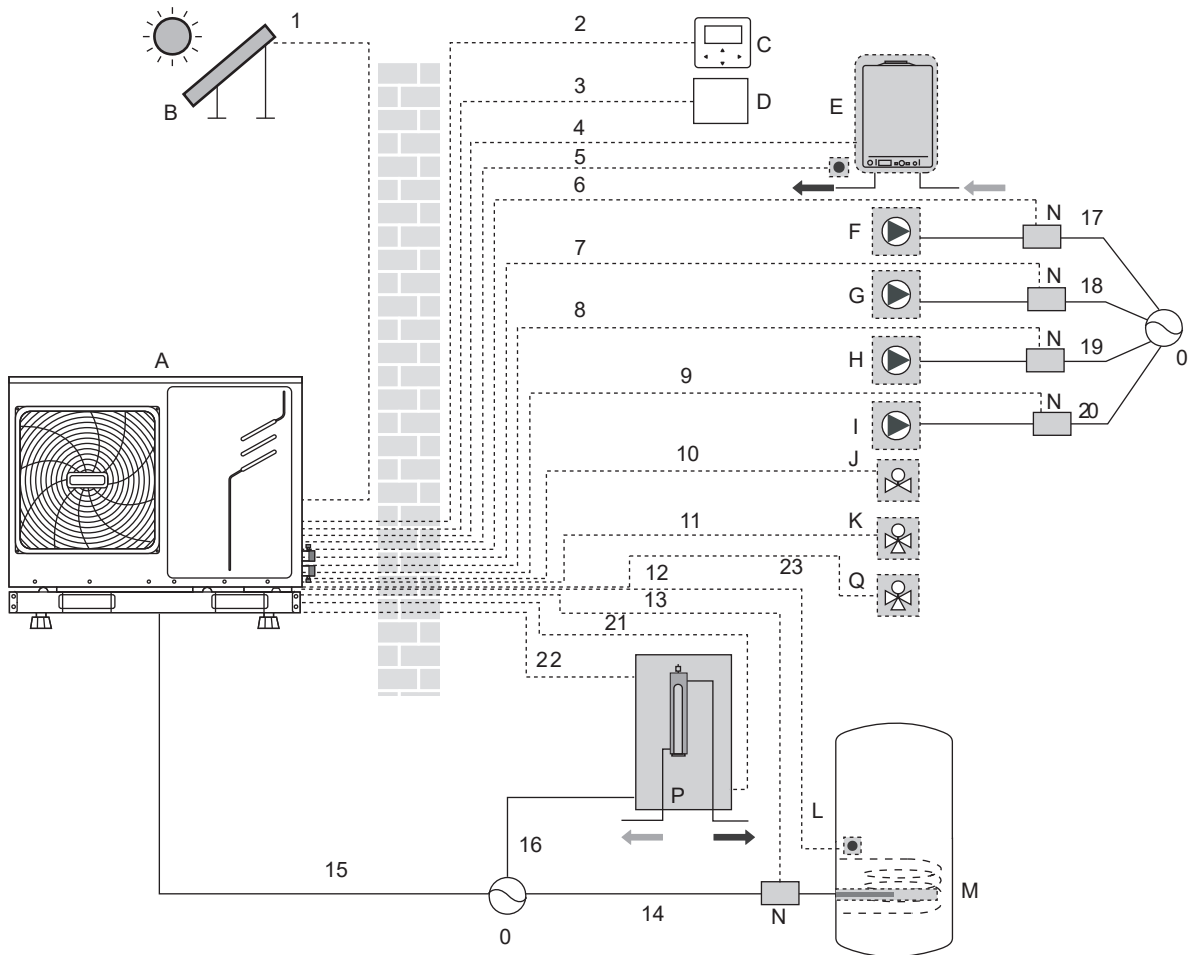

5/7/9kW

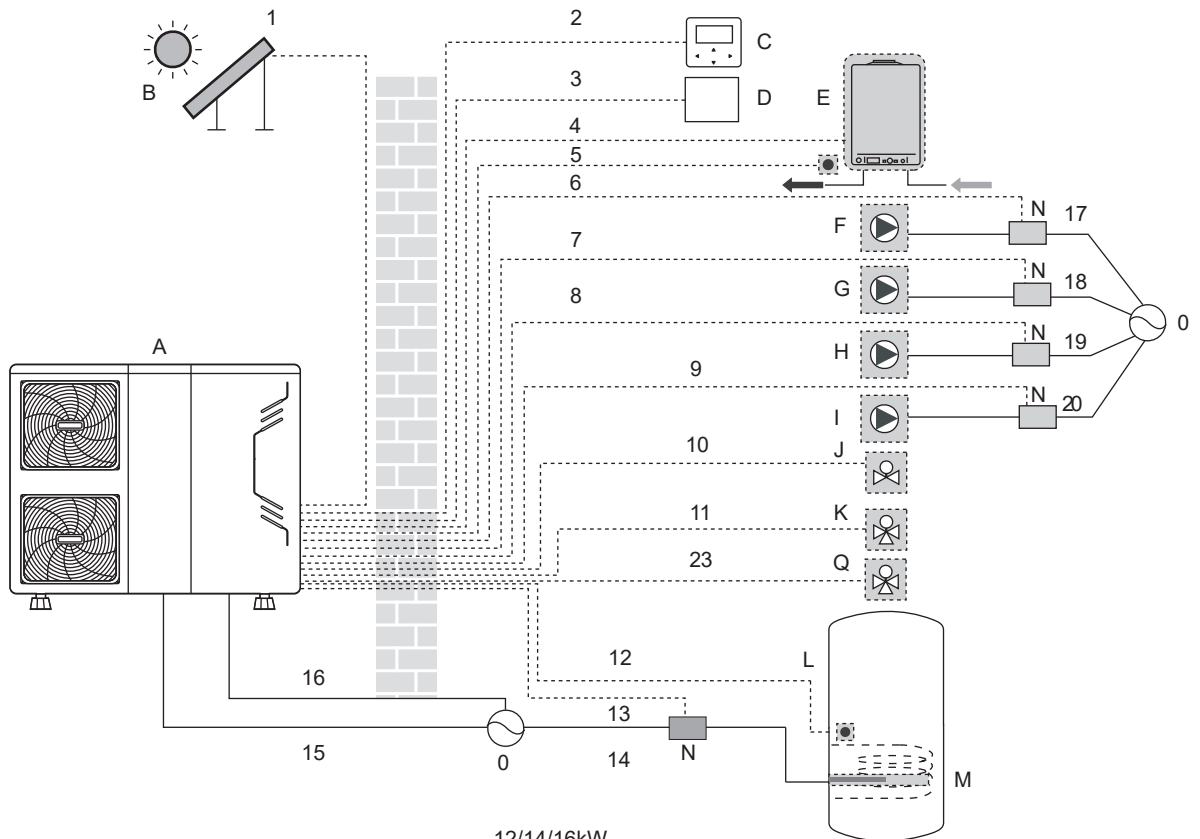

12/14/16kW

Coding	Assembly unit	Coding	Assembly unit
A	Outdoor unit	J	SV2: 2-way valve (field supply)
B	Solar energy kit (field supply)	K	SV1: 3-way valve for domestic hot water tank (field supply)
C	User interface	L	Domestic hot water tank
D	Room thermostat (field supply)	M	Booster heater
E	Boiler (field supply)	N	Contactora
F	P_s: Solar pump (field supply)	O	Power supply
G	P_c: Mixing pump (field supply)	P	Backup heater
H	P_o: Outside circulation pump (field supply)	Q	Zone2 SV3(3-way valve)
I	P_d: DHW pump (field supply)		

Item	Description	AC/DC	Required number of conductors	Maximum running current
1	Solar energy kit signal cable	AC	2	200mA
2	User interface cable	AC	5	200mA
3	Room thermostat cable	AC	2 or 3	200mA(a)
4	Boiler control cable	/	2	200mA
5	Thermistor cable for T1B	DC	2	(b)
9	DHW pump control cable	AC	2	200mA(a)
10	2-way valve control cable	AC	2	200mA(a)
11	3-way valve control cable	AC	2 or 3	200mAC
12	Thermistor cable	DC	2	(b)
13	Booster heater control cable	AC	2	200mA(a)
15	Power supply cable for unit	AC	2+GND(1-Phase) 3+GND(3-Phase)	31A (1-Phase) 15A (3-Phase)
16	Power supply cable for backup heater	AC	2+GND(1-Phase) 3+GND(3-Phase)	14A (1-Phase) 6A (3-Phase)

(a) Minimum cable section AWG18 (0.75 mm²).

(b)The thermistor cable are delivered with the unit: if the current of the load is large, an AC contactor is needed.

NOTE

Please use H07RN-F for the power wire, all the cable are connect to high voltage except for thermistor cable and cable for user interface.

- Equipment must be grounded.
- All high-voltage external load, if it is metal or a grounded port, must be grounded.
- All external load current is needed less than 0.2A, if the single load current is greater than 0.2A, the load must be controlled through AC contactor.
- AHS1" "AHS2", "A1" "A2", "R1" "R1" and "DTF1" "DTF2" wiring terminal ports provide only the switch signal. Please refer to image of 9.7.6 to get the ports position in the unit.
- Expansion valve E-Heating tape, Plate heat exchanger E-Heating tape and Flow switch E-Heating tape share a control port.

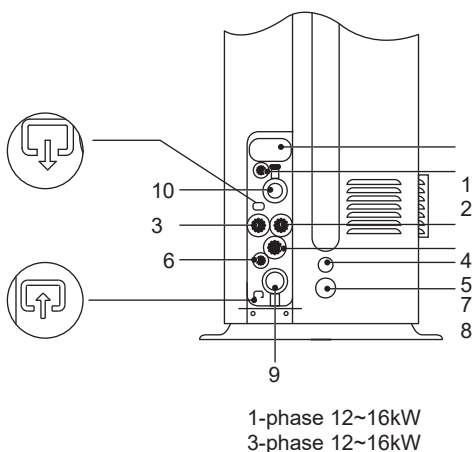

Coding	Assembly unit
1	High voltage wire hole
2	Low voltage wire hole
3	High voltage wire hole
4	Compressor connection port W
5	Drainage pipe hole
6	Low voltage wire hole
7	Low voltage wire hole(backup)
8	Low voltage wire hole(backup)
9	Water inlet
10	Water outlet

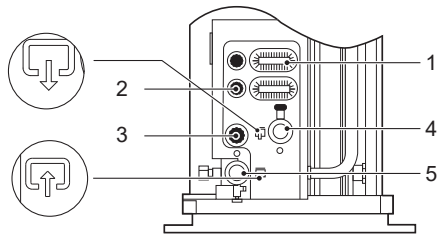

1-phase 5/7/9 kW

Coding	Assembly unit
1	High voltage wire hole
2	Low voltage wire hole
3	Drainage pipe hole
4	Water outlet
5	Water inlet

Field wiring guidelines

- Most field wiring on the unit is to be made on the terminal block inside the switch box. To gain access to the terminal block, remove the switch box service panel (door 2).

⚠ WARNING

Switch off all power including the unit power supply and backup heater and domestic hot water tank power supply (if applicable) before removing the switch box service panel.

- Fix all cables using cable ties.
- A dedicated power circuit is required for the backup heater.
- Installations equipped with a domestic hot water tank (field supply) require a dedicated power circuit for the booster heater. Please refer to the domestic hot water tank Installation & Owner's Manual. Secure the wiring in the order shown below.
- Lay out the electrical wiring so that the front cover does not rise up when doing wiring work and attach the front cover securely.
- Follow the electric wiring diagram for electrical wiring works (the electric wiring diagrams are located on the rear side of door 2).
- Install the wires and fix the cover firmly so that the cover may be fit in properly.

9.7.3 Precautions on wiring of power supply

- Use a round crimp-style terminal for connection to the power supply terminal board. In case it cannot be used due to unavoidable reasons, be sure to observe the following instructions.
 - Do not connect different gauge wires to the same power supply terminal. (Loose connections may cause overheating.)
 - When connecting wires of the same gauge, connect them according to the figure below.

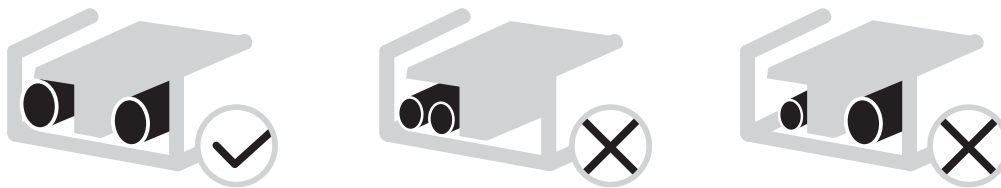

- Use the correct screwdriver to tighten the terminal screws. Small screwdrivers can damage the screw head and prevent appropriate tightening.
- Over-tightening the terminal screws can damage the screws.
- Attach a ground fault circuit interrupter and fuse to the power supply line.
- In wiring, make certain that prescribed wires are used, carry out complete connections, and fix the wires so that outside force cannot affect the terminals.

9.7.4 Specifications of standard wiring components

Door 1: compressor compartment and electrical parts: XT1

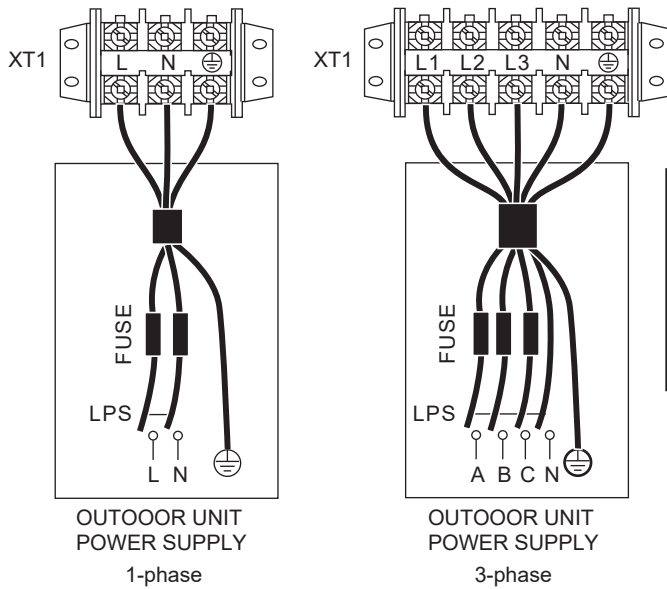

Unit(kW)	1-phase		3-phase
	5/7/9	12~16	12~16
Maximum overcurrent protector(MOP)	20	30	15
Wiring size(mm ²)	4	6	4

- Stated values are maximum values (see electrical data for exact values).

NOTE

The ground fault circuit interrupter must be a high-speed type breaker of 30 mA (<0.1 s).

9.7.5 Connection of the backup heater power supply(This section is intended only for models that contain backup heater.)

Power circuit and cable requirements

CAUTION

Be sure to use a dedicated power circuit for the backup heater. Never use a power circuit shared by another appliance.
Use the same dedicated power supply for the unit, backup heater and booster heater (domestic hot water tank).

This power circuit must be protected with the required safety devices according to local laws and regulations.

Select the power cable in accordance with relevant local laws and regulations. For the maximum running current of the backup heater, refer to the table below.

Door 2: electrical parts of the hydraulic compartment, backup heater: XT5 (3-phase) /XT4(1-phase)

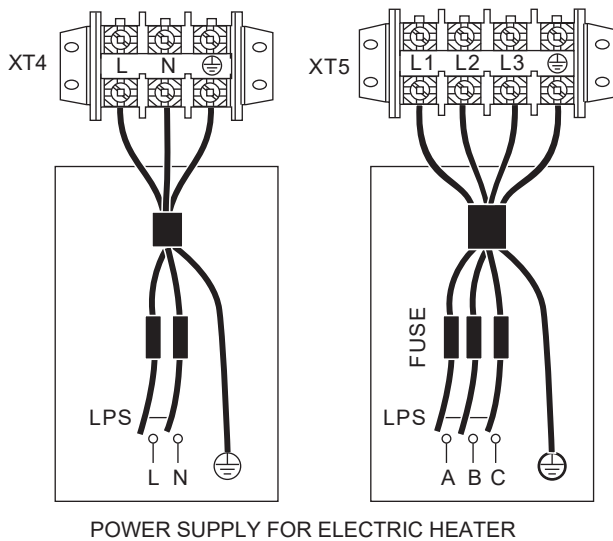

Unit(kW)	Backup heater capacity	
	1-phase	3-phase
	3	4.5
Backup heater nominal voltage	220-240VAC	380-415VAC
Minimum circuit amps (MCA)	14.3	6.0
Maximum overcurrent protector(MOP)	20	10
Wiring size(mm ²)	4	2.5

NOTE

The ground fault circuit interrupter must be a high-speed type breaker of 30 mA (<0.1 s).

9.7.6 Connection for other components

Unit 5~9kW

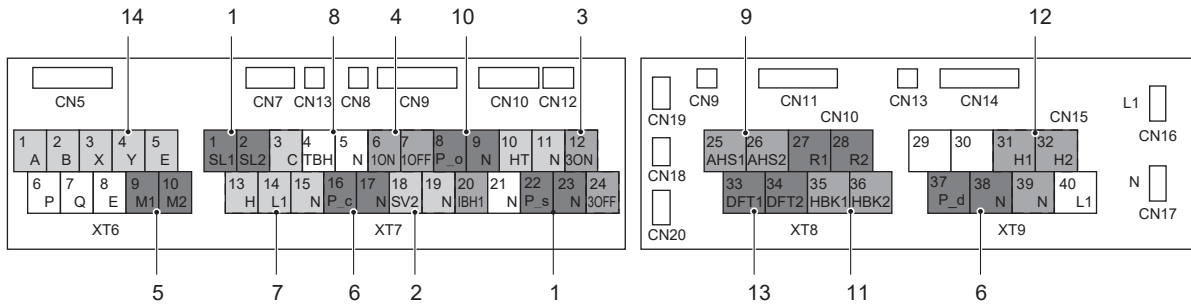

Unit 12~16kW

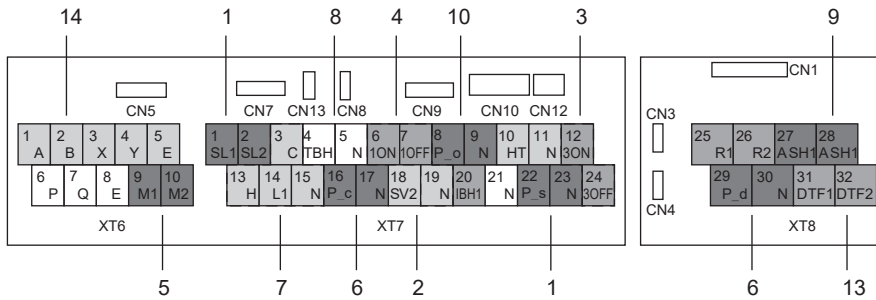

Coding	Assembly unit	Coding	Assembly unit
1	Solar input / Pump_S	8	DHW electric back heating
2	SV2	9	Additional heat source
3	SV3(3-way valve of Zone2)	10	Pump_O
4	SV1(3-way valve)	11	Feedback switch signal input
5	Remote shut down	12	External backup heater kit
6	Pump_C/ Pump_D	13	Defrosting prompt signal
7	Room thermostat	14	Wired Controller

Port provide the control signal to the load.Two kind of control signal port:

Type 1: Dry connector without voltage.

Type 2: Port provide the signal with 220V voltage. If the current of load is <0.2A, load can connect to the port directly.

If the current of load is >=0.2A, the AC contactor is required to connected for the load.

WIRING: transfer board/13 to 40 connection priority.

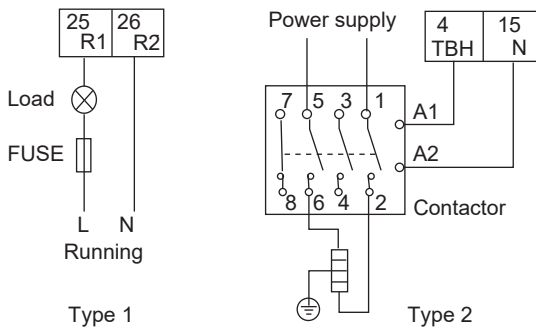

1) For solar energy kit

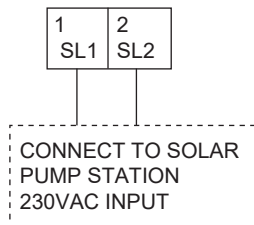

Voltage	220-240VAC
Maximum running current(A)	0.2
Wiring size(mm ²)	0.75

Control signal port of hydraulic model : The XT6-XT9 contains terminals for solar energy, remote alarm, 2-way valve, 3-way valve, pump, booster heater and external heating source, etc.

The parts wiring is illustrated below:

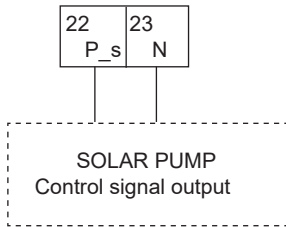

Voltage	220-240VAC
Minimum circuit amps (MCA)	0.2
Wiring size(mm ²)	0.75
Control port signal type	Type 2

2) For 2-way valve SV2:

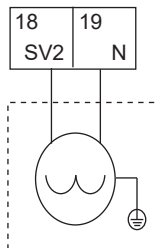

Voltage	220-240VAC
Maximum running current(A)	0.2
Wiring size(mm ²)	0.75
Control port signal type	Type 2

NOTE

Only a normal closing valve is available for this unit

a) Procedure

- Connect the cable to the appropriate terminals as shown in the picture.
- Fix the cable reliably.

3) For 3-way valve SV3

4) For 3-way valve SV1

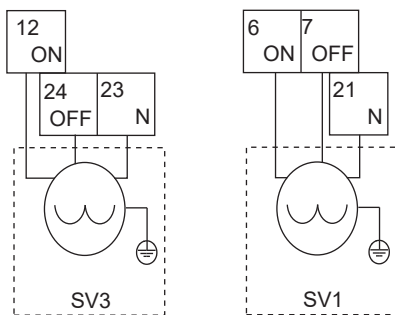

Voltage	220-240VAC
Maximum running current(A)	0.2
Wiring size(mm ²)	0.75
Control port signal type	Type 2

NOTE

Wiring of the 3-way valve is different for NC(normal close) and NO (normal open). Before wiring, read the Installation & Owner's manual for the 3-way valve carefully and install the valve as showed in the picture. Make sure to connect it to the correct terminal numbers.

a) Procedure

- Connect the cable to the appropriate terminals as shown in the picture.
- Fix the cable reliably.

5) For remote shut down:

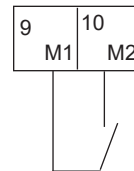

CLOSE: SHUT DOWN

6) For tank loop pump P_d and mix pump P_c:

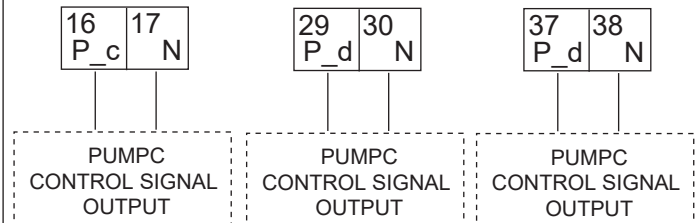

NOTE

For 5/7/9 kW units, the terminal number is 37 and 38. For 12/14/16 kW units, the terminal number is 29 and 30.

Voltage	220-240VAC
Maximum running current(A)	0.2
Wiring size(mm ²)	0.75
Control port signal type	Type 2

a) Procedure

- Connect the cable to the appropriate terminals as shown in the picture.
- Fix the cable reliably.

7) For room thermostat:

Room thermostat type 1(RT1) (High voltage)

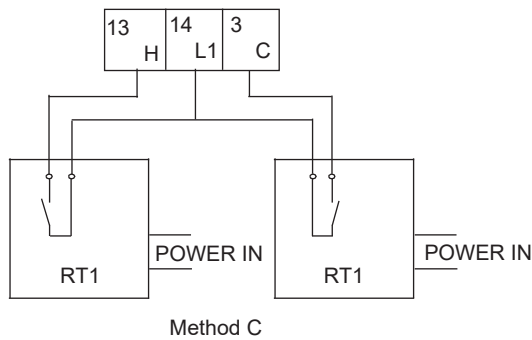
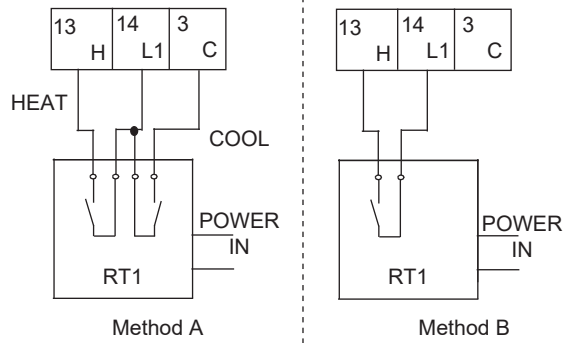

Room thermostat type2 (RT2) (Low voltage):

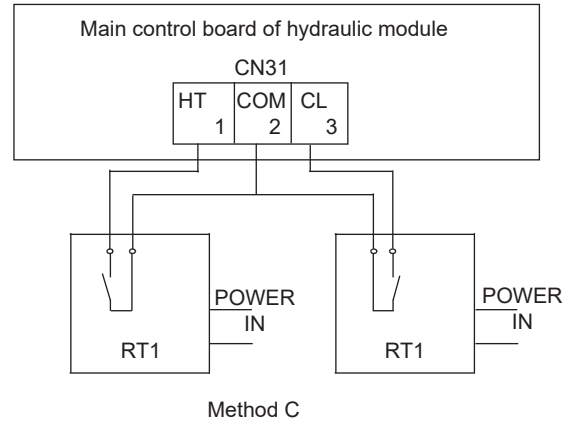
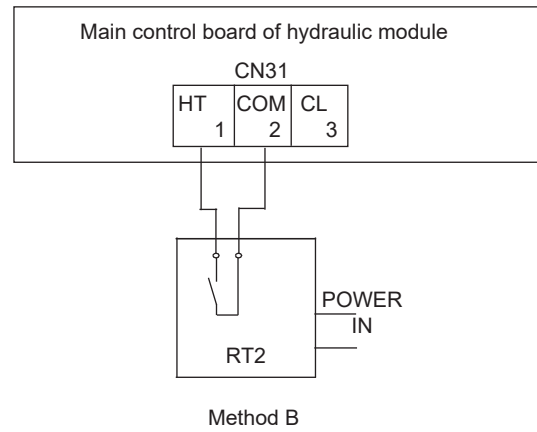
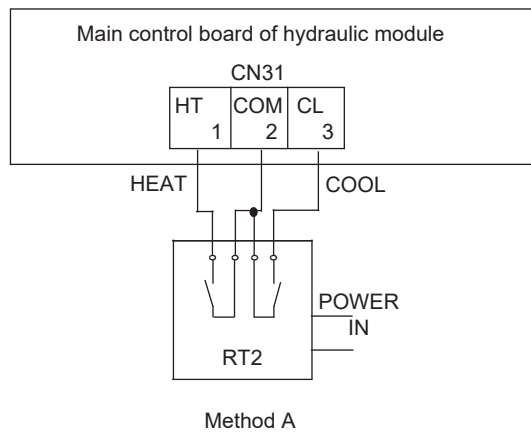

Voltage	220-240VAC
Maximum running current(A)	0.2
Wiring size(mm ²)	0.75

NOTE

There are two optional connect method depend on the room thermostat type.

Room thermostat type 1(RT1)(High voltage): "POWER IN" provide the working voltage to the RT, doesn't provide the voltage to the RT connector directly. Port "14 L1" provide the 220V voltage to the RT connector. Port "14 L1" connect from the unit main power supply port L of 1- phase power supply, L2 port of 3-phase power supply.

Room thermostat type2(RT2)(Low voltage): "POWER IN" provide the working voltage to the RT.

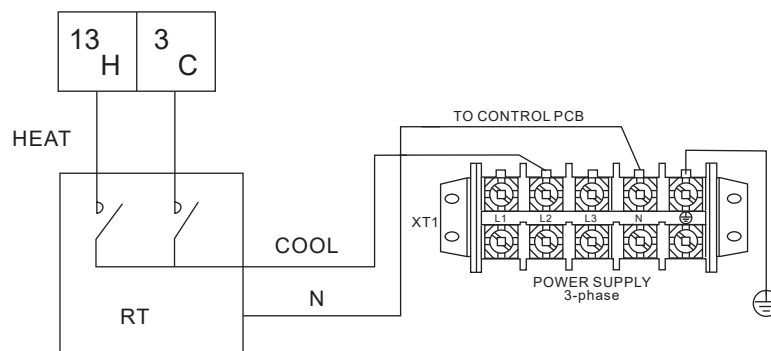

There are three methods for connecting the thermostat cable (as described in the picture above) and it depends on the application.

• **Method A**

RT can control heating and cooling individually, like the controller for 4-pipe FCU. When the hydraulic module is connected with the external temperature controller, user interface FOR SERVICEMAN set THERMOSTAT and ROOM MODE SETTING to YES:

- A.1 When unit detect voltage is 230VAC between C and N ,the unit operates in the cooling mode.
- A.2 When unit detect voltage is 230VAC between H and N, the unit operates in the heating mode.
- A.3 When unit detect voltage is 0VAC for both side(C-N, H-N) the unit stop working for space heating or cooling.
- A.4 When unit detect voltage is 230VAC for both side(C-N, H-N) the unit working in cooling mode.

• **Method B**

RT provide the switch signal to unit. user interface FOR SERVICEMAN set ROOM THERMOSTAT and MODE SETTING to YES:

- B.1 When unit detect voltage is 230VAC between H and N, unit turn on.
- B.2 When unit detect voltage is 0VAC between H and N, unit turn off.

NOTE

When ROOM THERMOSTAT is set to YES, the indoor temperature sensor Ta can't be set to valid, unit running only according to T1.

• **Method C**

Hydraulic module is connected with two external temperature controllers, while user interface FOR SERVICEMAN set DUAL ROOM THERMOSTAT to YES:

- C.1 When unit detect voltage is 230VAC between H and N ,the MAIN side turn on.When unit detect voltage is 0VAC between H and N, the MAIN side turn off.
- C.2 When unit detect voltage is 230VAC between C and N, the ROOM side turn on according to climate temp curve. When unit detect voltage is 0V between C and N, the ROOM side turn off.
- C.3 When H-N and C-N are detected as 0VAC, unit turn off.
- C.4 when H-N and C-N are detected as 230VAC, both MAIN and ROOM side turn on.

NOTE

- The wiring of the thermostat should correspond to the settings of the user interface. Refer to 10.7 Field setting/Room Thermostat.
- Power supply of machine and room thermostat must be connected to the same Neutral Line and (L2) Phase Line(for 3-phase unit only).

a) Procedure

- Connect the cable to the appropriate terminals as shown in the picture.
- Fix the cable with cable ties to the cable tie mountings to ensure stress relief.

8) For booster heater:

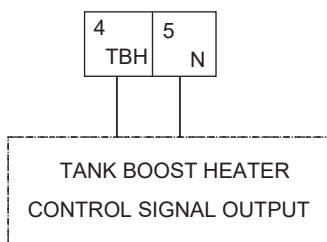

Voltage	220-240VAC
Maximum running current(A)	0.2
Wiring size(mm ²)	0.75
Control port signal type	Type 2

Connection of the booster heater cable depends on the application. Only when the domestic hot water tank is installed will this wiring be needed. The unit only sends a turn on/off signal to the booster heater. An additional circuit breaker is needed and a dedicated terminal is needed to supply power to the booster heater.

See also "8 Typical application examples" and "10.7 Field settings/DHW control" for more information.

a) Procedure

- Connect the cable to the appropriate terminals as shown in the picture.
- Fix the cable with cable ties to the cable tie mountings to ensure stress relief.

8) For additional heat source control:

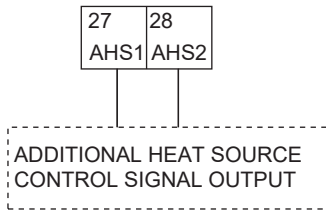

For 5/7/9 kW unit, the terminal number is 25 and 26.

Voltage	220-240VAC
Maximum running current(A)	0.2
Wiring size(mm ²)	0.75
Control port signal type	Type 2

10) For outside circulation pump P_o:

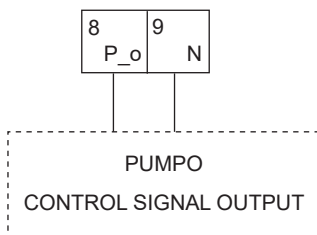

Voltage	220-240VAC
Maximum running current(A)	0.2
Wiring size(mm ²)	0.75
Control port signal type	Type 2

a) Procedure

- Connect the cable to the appropriate terminals as shown in the picture.
- Fix the cable with cable ties to the cable tie mountings to ensure stress relief.

11) For feedback switch signal input(5/7/9 kW unit only, reserved):

IBH1/2 FEEDBACK INPUT
(SWITCH SIGNAL INPUT)

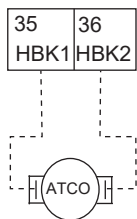

RESERVED

Atco: auto reset thermal protector
It must be connected to thermal protector!

12) For external backup heater kit (optional) (5/7/9kW unit only)

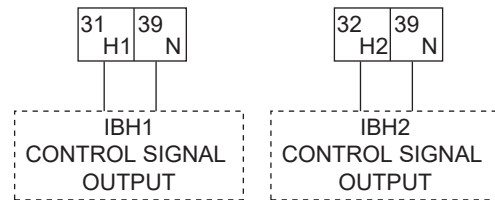

13) For defrosting signal output:

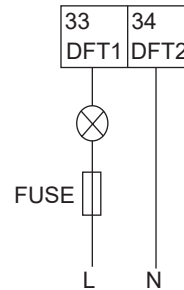

DEFROSTING PROMPT SIGNAL

Voltage	220-240VAC
Maximum running current(A)	0.2
Wiring size(mm ²)	0.75
Control port signal type	Type 1

14) For wired controller:

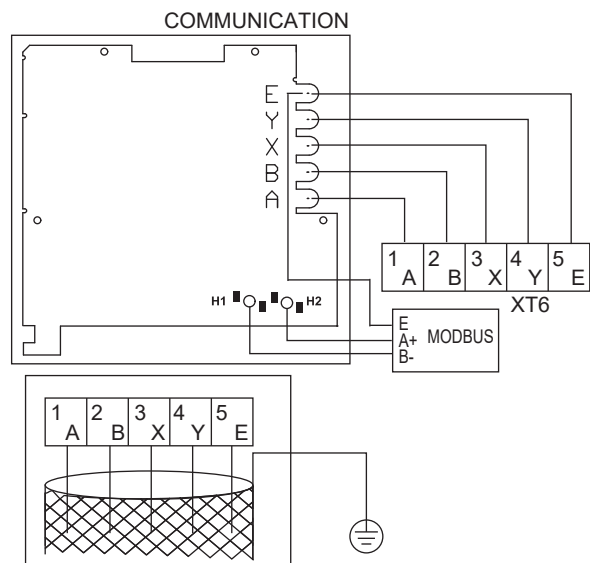

"PLEASE USE SHIELDED WIRE AND EARTH THE WIRE."

NOTE

This equipment supports MODBUS RTU communication protocol.

Wire type	5 wire shielded cable
Wire section(mm ²)	0.75~1.25
Maximum wire length(m)	50

As described above, during wiring, port A in the unit terminal XT6 corresponds to port A in the user interface. Port B corresponds to port B. Port X corresponds to port X. Port Y corresponds to port Y, and port E corresponds to port E.

a) Procedure

- Remove the rear part of the user interface.
- Connect the cable to the appropriate terminals as shown in the picture.
- Reattach the rear part of the user interface.

15) For smart grid:

The unit has smart grid function, there are two ports on PCB to connect SG signal and EVU signal as following:

1. when EVU signal closed, the unit operate as below:
DHW mode turn on, the setting temperature will be changed to 70 C automatically, and the TBH operate as below: $T5 < 69$. the TBH is on, $T5 \geq 70$, the TBH is off. The unit operate in cooling/heating mode as the normal logic.
2. When EVU signal is open, and SG signal is closed, the unit operate normally.
3. When EVU signal is open, SG signal is open, the DHW mode is off, and the TBH is invalid, dis-infect function is invalid. The max running time for cooling/heating is "SG RUNNIN TIME", then unit will be off.

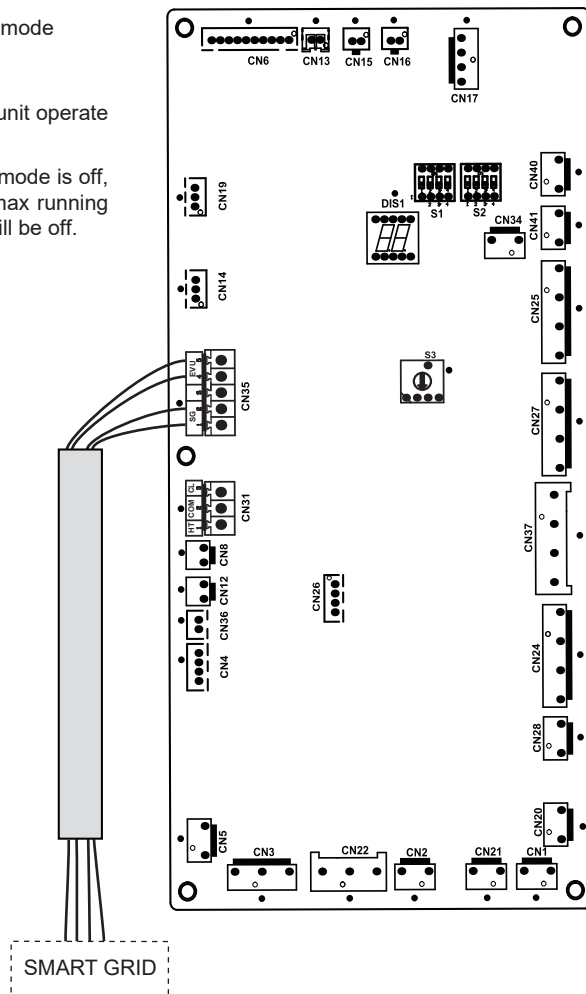

10 START-UP AND CONFIGURATION

The unit should be configured by the installer to match the installation environment (outdoor climate, installed options, etc.) and user expertise.

⚠ CAUTION

It is important that all information in this chapter is read sequentially by the installer and that the system is configured as applicable.

10.1 Climate related curves

The Climate related curves can be selected in the user interface. Once the curve is selected, the target outlet temperature. In each mode, user can select one curve from curves in the user interface (curve can't be selected if dual room thermostat function is enabled).

It's possible to select curves even dual room thermostat function is enabled. This function is for customized .

The relationship between outdoor temperature ($T4/^{\circ}\text{C}$) and the target water temperature ($T1S/^{\circ}\text{C}$) is described in the table and picture in the next page.)

NOTE

If dual room thermostat function is enabled, only curve 4 can be used, for customazition product, curve selection is possible even dual room thermalstat function is enabled.

Temperature curves for heating mode and ECO heating mode

Application	Curve number	Outdoor Temperatures T4											
		T1s	-20	-15	-10	-5	0	5	10	15	20	25	35
Low temperature	1		38	37	36	36	35	34	33	33	32	32	32
	2		35	34	34	33	32	32	31	31	30	30	30
	3		33	33	32	32	31	31	31	30	30	30	30
	4		35	34	33	32	31	31	30	29	28	28	28
	5		33	32	32	31	30	30	29	29	28	28	28
	6		31	30	30	29	28	28	27	27	26	26	26
	7		29	29	28	28	27	27	27	26	26	26	26
	8		29	28	28	27	26	26	25	25	24	24	24
High temperature	1		55	54	54	53	52	52	51	51	50	50	50
	2		55	54	52	51	50	49	47	46	45	45	45
	3		55	53	51	49	47	45	44	42	40	40	40
	4		50	49	49	48	47	47	46	46	45	45	45
	5		50	49	47	46	45	44	42	41	40	40	40
	6		45	44	44	43	42	42	41	41	40	40	40
	7		45	44	42	41	40	39	37	36	35	35	35
	8		40	39	39	38	37	37	36	36	35	35	35

Temperature curves for Cooling mode

Application	Curve number	Outdoor Temperatures T4				
		T1s	-5~14	15~21	22~29	30~46
Low temperature	1		18	11	8	5
	2		17	12	9	6
	3		18	13	10	7
	4		19	14	11	8
	5		20	15	12	9
	6		21	16	13	10
	7		22	17	14	11
	8		23	18	15	12
High temperature	1		22	20	18	16
	2		20	19	18	17
	3		23	21	19	17
	4		21	20	19	18
	5		24	22	20	18
	6		22	21	20	19
	7		25	23	21	19
	8		23	22	21	20

Low temperature curves for heating mode

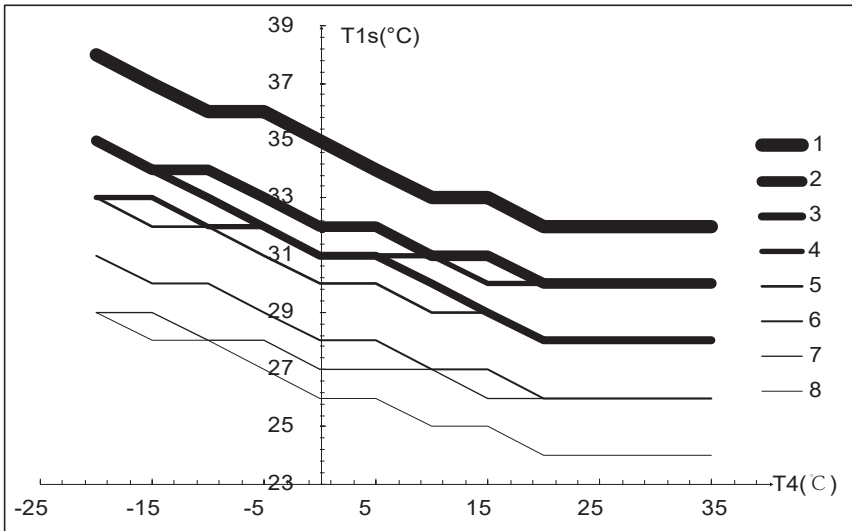

High temperature curves for heating mode

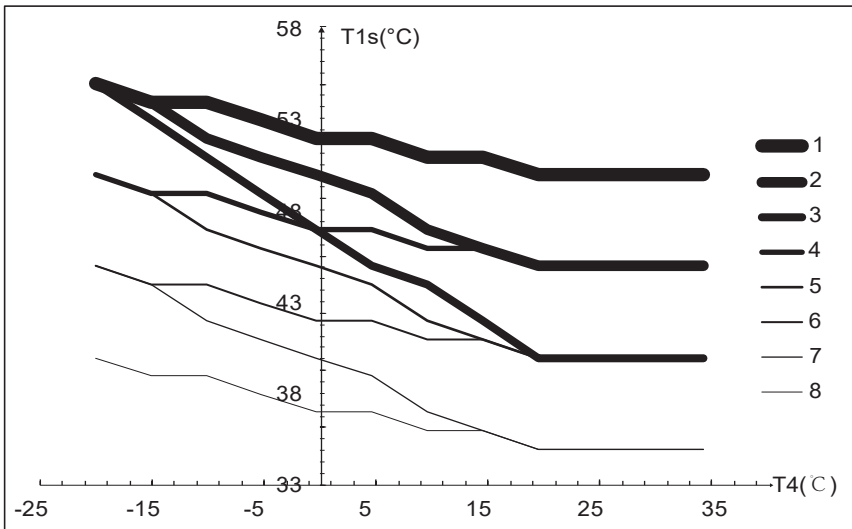

Low temperature curves for cooling mode

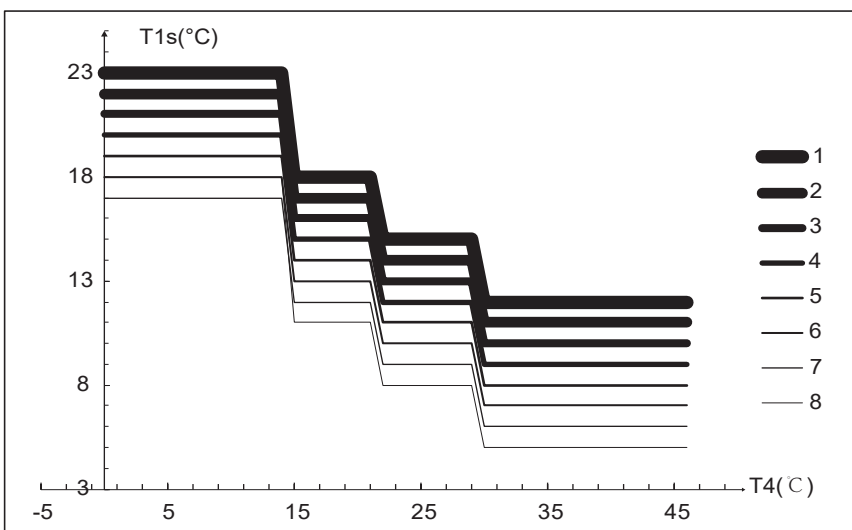

High temperature curves for cooling mode

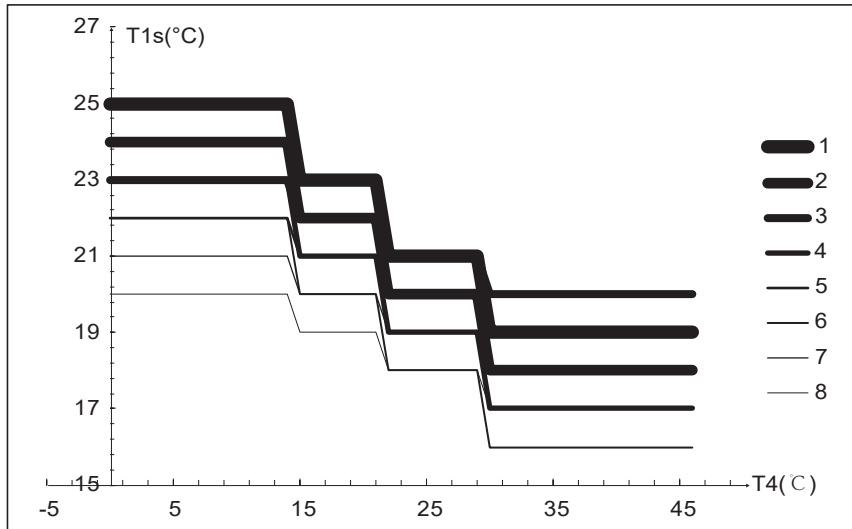

10.2 DIP switch settings overview

10.2.1 Function setting

DIP switch 13 is located on the hydraulic module main control board (see "9.3.1 main control board of hydraulic module") and allows configuration of additional heating source thermistor installation, the second inner backup heater installation, etc.

⚠ WARNING

Switch off the power supply before opening the switch box service panel and making any changes to the DIP switch settings.

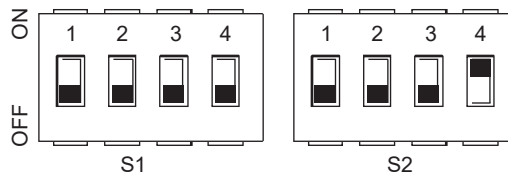

DIP switch	ON=1	OFF=0	Factory default	DIP switch	ON=1	OFF=0	Factory default		
S1	1	Reserved	Reserved	OFF	S2	1	Start outside circulator pump after six hours will be invalid	Start outside circulator pump after six hours will be valid	OFF
	2	With solar energy	Without solar energy	OFF		2	Without TBH	With TBH	OFF
	3/4	0/0=Without IBH and AHS 0/1=With AHS for heat mode 1/0=With IBH 1/1=With AHS for heat mode and DHW mode		3:OFF 4:OFF		3/4	0/0=variable speed pump (Max head:8.5m) 0/1=constant speed pump 1/0=variable speed pump(reserved) 1/1=variable speed pump (Max head:9m)		3:OFF 4:ON

10.3 Initial start-up at low outdoor ambient temperature

During initial start-up and when water temperature is low, it is important that the water is heated gradually. Failure to do so may result in concrete floors cracking due to rapid temperature change. Please contact the responsible cast concrete building contractor for further details.

To do so, the lowest water flow set temperature can be decreased to a value between 25°C and 35°C by adjusting the FOR SERVICEMAN. Refer to "FOR SERVICEMAN/special function/preheating for floor" .

10.4 Pre-operation checks

Checks before initial start-up.

⚠ DANGER

Switch off the power supply before making any connections.

After the installation of the unit, check the following before switching on the circuit breaker:

- **Field wiring:** Make sure that the field wiring between the local supply panel and unit and valves (when applicable), unit and room thermostat (when applicable), unit and domestic hot water tank, and unit and backup heater kit have been connected according to the instructions described in the chapter 9.6 Field wiring, according to the wiring diagrams and to local laws and regulations.
- **Fuses, circuit breakers, or protection devices** Check that the fuses or the locally installed protection devices are of the size and type specified in the chapter 14 Technical specifications. Make sure that no fuses or protection devices have been bypassed.
- **Backup heater circuit breaker:** Do not forget to turn on the backup heater circuit breaker in the switchbox (it depends on the backup heater type). Refer to the wiring diagram.
- **Booster heater circuit breaker:** Do not forget to turn on the booster heater circuit breaker (applies only to units with optional domestic hot water tank installed).
- **Ground wiring:** Make sure that the ground wires have been connected properly and that the ground terminals are tightened.
- **Internal wiring:** Visually check the switch box for loose connections or damaged electrical components.
- **Mounting:** Check that the unit is properly mounted, to avoid abnormal noises and vibrations when starting up the unit.
- **Damaged equipment:** Check the inside of the unit for damaged components or squeezed pipes.
- **Refrigerant leak:** Check the inside of the unit for refrigerant leakage. If there is a refrigerant leak, call your local dealer.
- **Power supply voltage:** Check the power supply voltage on the local supply panel. The voltage must correspond to the voltage on the identification label of the unit.
- **Air purge valve:** Make sure the air purge valve is open (at least 2 turns).
- **Shut-off valves:** Make sure that the shut-off valves are fully open.

10.5 Powering up the unit

When power to the unit is turned on, "1%~99%" is displayed on the user interface during initialization. During this process the user interface cannot be operated.

10.6 Setting the pump speed

The pump speed can be selected by adjusting the red knob on the pump. The notch point indicates pump speed.

The default setting is the highest speed (III). If the water flow in the system is too high the speed can be set to low (I).

The available external static pressure function for water flow is shown in the graph below.

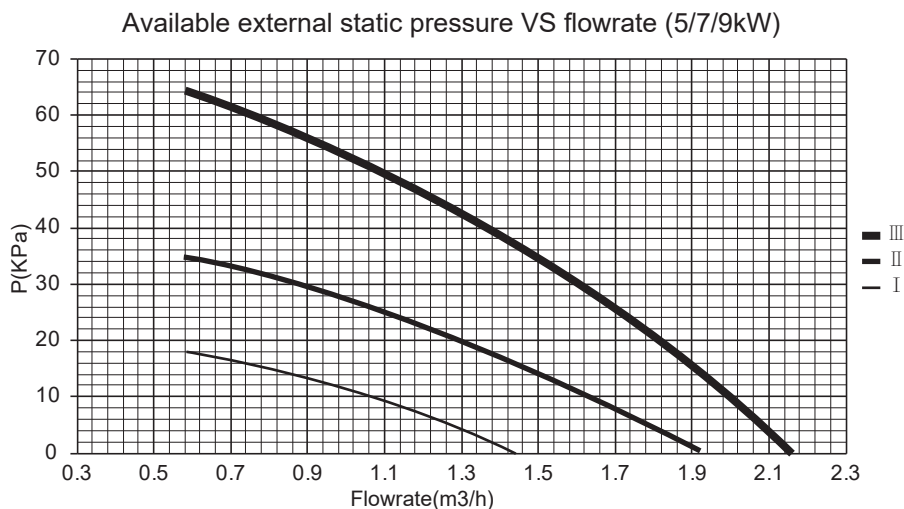
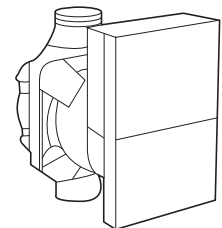

⚠ DANGER

Operating the system with closed valves will damage the circulation pump!

Available external static pressure VS flowrate (12~16kW)

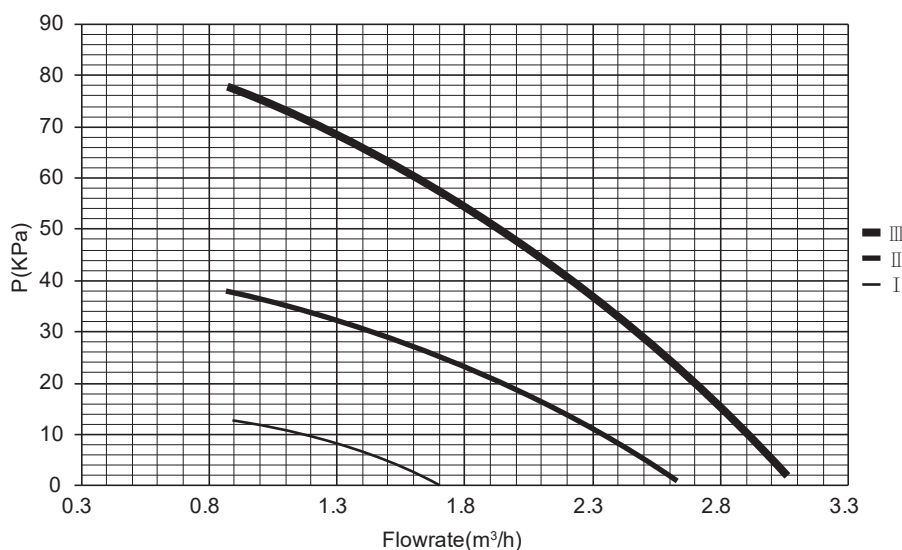

⚠ DANGER

If it's necessary to check the running status of the pump when unit power on, please do not touch the internal electronic control box components to avoid electric shock.

1) Pump LED diagnosis and solutions

The pump has an LED operating status display. This makes it easy for the technician to search for the cause of a fault in the heating system.

- If the LED display lights up continuously green, it means the pump is running normally.
- If the LED display is flashing green, it means the pump is running the venting function. The pump runs during the 10 minute venting function. After its cycle, the installer needs to adjust the targeted performance.
- If the LED is flashing green/red, it means that the pump has stopped operating due to an external reason. The pump will restart by itself after the abnormal situation disappears. The probable reason causing the problem is pump undervoltage or overvoltage ($U < 160V$ or $U > 280V$), and you should check the voltage supply. Another reason is module overheating, and you should check the water and ambient temperatures.
- If the LED is flashing red, it means the pump has stopped operating, and a serious fault has happened (e.g. pump blocked). The pump cannot restart itself due to a permanent failure and the pump should be changed.
- If the LED does not light up, it means no power supply to the pump, possibly the pump is not connected to power supply. Check the cable connection. If the pump is still running, it means the LED is damaged. Or the electronics are damaged and the pump should be changed.

2) Failure diagnosis at the moment of first installation

- If nothing is displayed on the user interface, it is necessary to check for any of the following abnormalities before diagnosing possible error codes.
 - Disconnection or wiring error (between power supply and unit and between unit and user interface).
 - The fuse on the PCB may have blown.
- If the user interface shows "E8" or "E0" as an error code, there is a possibility that there is air in the system, or the water level in the system is less than the required minimum.
- If the error code E2 is displayed on the user interface, check the wiring between the user interface and unit.

More error code and failure causes can be found in 13.4 Error codes.

10.7 Field settings

The unit shall be configured by the installer to match the installation environment (outdoor climate, installed options, etc.) and user demand. A number of field settings are available. These settings are accessible and programmable through "FOR SERVICEMAN" in user interface.

Powering on the unit

When power on the unit, "1%~99%" is displayed on the user interface during initialization. During this process the user interface cannot be operated.

Procedure

To change one or more field settings, proceed as follows.

NOTE

Temperature values displayed on the wired controller (user interface) are in °C.

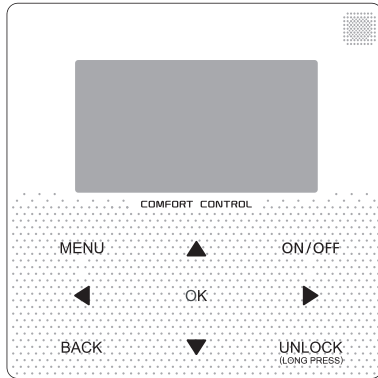

Keys	Function
MENU	• Go to the menu structure(on the home page)
◀▶▼▲	• Navigate the cursor on the display • Navigate in the menu structure • Adjust settings
ON/OFF	• Turn on/off the space heating/cooling operation or DHW mode • Turn on/or off functions in the menu structure
BACK	• Come back to the up level
UNLOCK	• Long press for unlock /lock the controller • Unlock /lock some functions such as "DHW temperature adjusting"
OK	• Go to the next step when programming a schedule in the menu structure; and confirm a selection to enter in the submenu of the menu structure.

About FOR SERVICEMAN

"FOR SERVICEMAN" is designed for the installer to set the parameters.

- Setting the composition of equipment.
- Setting the parameters.

How to go to FOR SERVICEMAN

Go to MENU> FOR SERVICEMAN. Press OK:

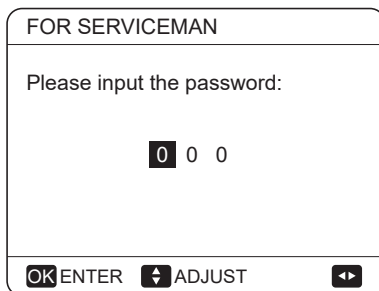

Press ◀ ▶ to navigate and press ▼ ▲ to adjust the numerical value. Press OK. The password is 234, the following pages will be displayed after putting the password:

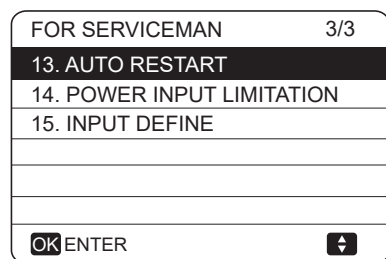
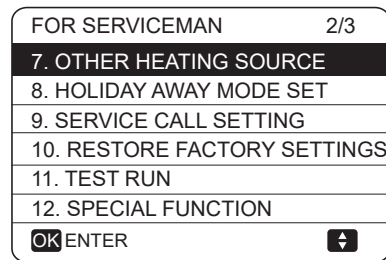
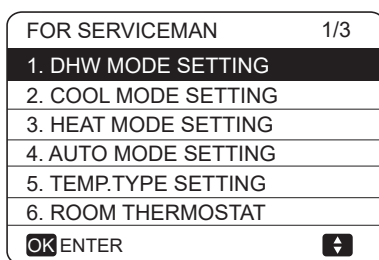

Press ▼ ▲ to scroll and use "OK" to enter submenu.

10.7.1 DHW MODE SETTING

DHW = domestic hot water

Go to MENU> FOR SERVICEMAN> 1.DHW MODE SETTING. Press OK. The following pages will be displayed:

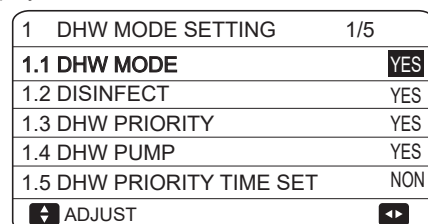

1 DHW MODE SETTING	2/5
1.6 dT5_ON	5 °C
1.7 dT1S5	10°C
1.8 T4DHWMAX	43°C
1.9 T4DHWMIN	-10°C
1.10 t_INTERVAL_DHW	5 MIN
ADJUST	

1 DHW MODE SETTING	3/5
1.11 dT5_TBH_OFF	5 °C
1.12 T4_TBH_ON	5 °C
1.13 t_TBH_DELAY	30 MIN
1.14 T5S_DI	65°C
1.15 t_DI HIGHTEMP.	15MIN
ADJUST	

1 DHW MODE SETTING	4/5
1.16 t_DI_MAX	210 MIN
1.17 t_DHWHP_RESTRICT	30 MIN
1.18 t_DHWHP_MAX	120 MIN
1.19 DHWPUMP TIME RUN	YES
1.20 PUMP RUNNING TIME	5 MIN
ADJUST	

1 DHW MODE SETTING	5/5
1.21 DHW PUMP DI RUN	NON
ADJUST	

10.7.2 COOL MODE SETTING

Go to MENU> FOR SERVICEMAN> 2.COOL MODE SETTING. Press OK.

The following pages will be displayed:

2 COOL MODE SETTING	1/3
2.1 COOL MODE	YES
2.2 t_T4_FRESH_C	2.0HRS
2.3 T4CMAX	43°C
2.4 T4CMIN	20°C
2.5 dT1SC	5°C
ADJUST	

2 COOL MODE SETTING	2/3
2.6 dTSC	2°C
2.7 t_INTERVAL_C	5MIN
2.8 T1SetC1	10°C
2.9 T1SetC2	16°C
2.10 T4C1	35°C
ADJUST	

2 COOL MODE SETTING	3/3
2.11 T4C2	25°C
2.12 ZONE1 C-EMISSION	FCU
2.13 ZONE2 C-EMISSION	FLH
ADJUST	

10.7.3 HEAT MODE SETTING

Go to MENU>FOR SERVICEMAN> 3.HEAT MODE SETTING. Press OK. The following pages will be displayed:

3 HEAT MODE SETTING	1/3
3.1 HEAT MODE	YES
3.2 t_T4_FRESH_H	2.0HRS
3.3 T4HMAX	16°C
3.4 T4HMIN	-15°C
3.5 dT1SH	5°C
ADJUST	

3 HEAT MODE SETTING	2/3
3.6 dTSH	2°C
3.7 t_INTERVAL_H	5MIN
3.8 T1SetH1	35°C
3.9 T1SetH2	28°C
3.10 T4H1	-5°C
ADJUST	

3 HEAT MODE SETTING	3/3
3.11 T4H2	7°C
3.12 ZONE1 H-EMISSION	RAD.
3.13 ZONE2 H-EMISSION	FLH
3.14 t_DELAY_PUMP	2MIN
ADJUST	

10.7.4 AUTO MODE SETTING

Go to MENU> FOR SERVICEMAN> 4.AUTO MODE SETTING. Press OK, the following page will be displayed.

4 AUTO. MODE SETTING	
4.1 T4AUTOCMIN	25°C
4.2 T4AUTOHMAX	17°C
ADJUST	

10.7.5 TEMP. TYPE SETTING

About TEMP. TYPE SETTING

The TEMP. TYPE SETTING is used for selecting whether the water flow temperature or room temperature is used to control the ON/OFF of the heat pump.

When ROOM TEMP. is enabled, the target water flow temperature will be calculated from climate-related curves (refer to 10.1 "Climate related curves").

How to enter the TEMP. TYPE SETTING

Go to MENU> FOR SERVICEMAN> 5.TEMP. TYPE SETTING. Press OK. The following page will be displayed:

5 TEMP. TYPE SETTING	
5.1 WATER FLOW TEMP.	YES
5.2 ROOM TEMP.	NON
5.3 DOUBLE ZONE	NON
ADJUST	

If you only set WATER FLOW TEMP. to YES, or only set ROOM TEMP. to YES, The following pages will be displayed.

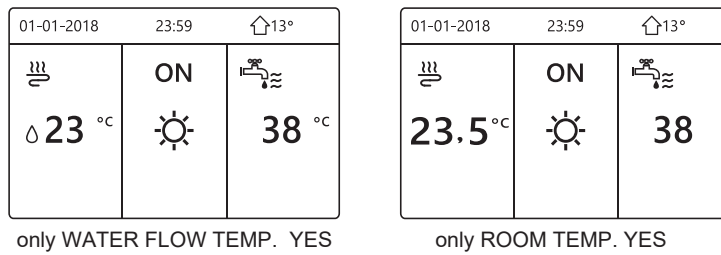

If you set WATER FLOW TEMP. and ROOM TEMP. to YES, meanwhile set DOUBLE ZONE to NON or YES, the following pages will be displayed.

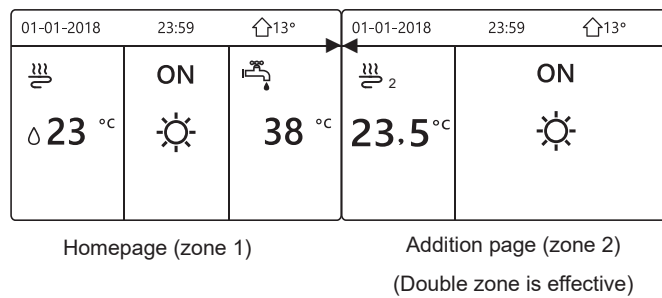

In this case, the setting value of zone 1 is T1S, the setting value of zone 2 is TS (The corresponding TIS2 is calculated according to the climate related curves.)

If you set DOUBLE ZONE to YES and set ROOM TEMP. to NON, meanwhile set WATER FLOW TEMP. to YES or NON, the following pages will be displayed.

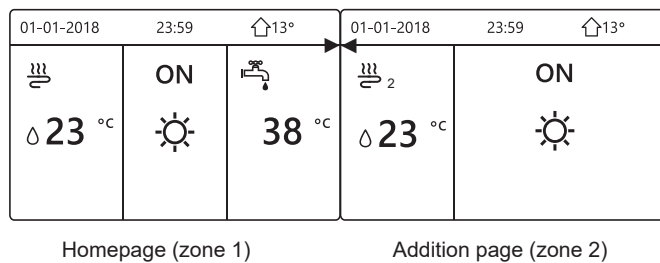

In this case, the setting value of zone 1 is T1S, the setting value of zone 2 is T1S2.

If you set DOUBLE ZONE and ROOM TEMP. to YES, meanwhile set WATER FLOW TEMP. to YES or NON, the following page will be displayed.

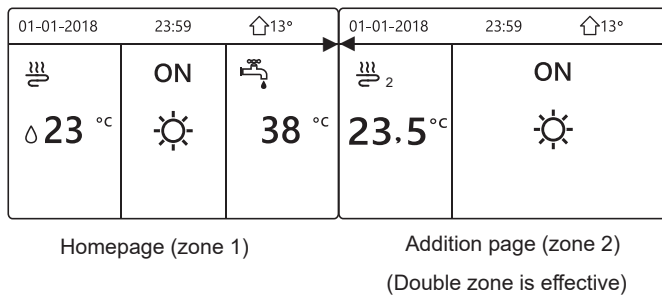

In this case, the setting value of zone 1 is T1S, the setting value of zone 1 is TS (The corresponding TIS2 is calculated according to the climate related curves.)

10.7.6 ROOM THERMOSTAT

About ROOM THERMOSTAT

The ROOM THERMOSTAT is used to set whether the room thermostat is available.

How to set the ROOM THERMOSTAT

Go to MENU> FOR SERVICEMAN> 6.ROOM THERMOSTAT. Press OK. The following page will be displayed:

6 ROOM THERMOSTAT
6.1 ROOM THERMOSTAT NON
ADJUST

NOTE

ROOM THERMOSTAT = NON, no room thermostat.

ROOM THERMOSTAT = MODE SET, the wiring of room thermostat should follow method A.

ROOM THERMOSTAT=ONE ZONE, the wiring of room thermostat should follow method B.

ROOM THERMOSTAT=DOUBLE ZONE, the wiring of room thermostat should follow method C (refer to **9.7.6 "Connection for other components/For room thermostat"**)

10.7.7 Other HEATING SOURCE

The OTHER HEATING SOURCE is used to set the parameters of the backup heater, additional heating sources and solar energy kit.

Go to MENU> FOR SERVICEMAN> 7.OTHER HEATING SOURCE, Press OK. The following page will be displayed:

7 OTHER HEATING SOURCE 1/2
7.1 dT1_IBH_ON 5°C
7.2 t_IBH_DELAY 30MIN
7.3 T4_IBH_ON -5°C
7.4 dT1_AHS_ON 5°C
7.5 t_AHS_DELAY 30MIN
ADJUST

7 OTHER HEATING SOURCE 2/2
7.6 T4_AHS_ON -5°C
ADJUST

10.7.8 HOLIDAY AWAY SETTING

The HOLIDAY AWAY SETTING is used to set the outlet water temperature to prevent freezing when away for holiday.

Go to MENU> FOR SERVICEMAN> 8.HOLIDAY AWAY SETTING. Press OK. The following page will be displayed:

8 HOLIDAY AWAY SETTING
8.1 T1S_H.A. H 20°C
8.2 T5S_H.A. DHW 20°C
ADJUST

10.7.9 SERVICE CALL SETTING

The installers can set the phone number of the local dealer in SERVICE CALL SETTING. If the unit doesn't work properly, call this number for help.

Go to MENU> FOR SERVICEMAN>SERVICE CALL. Press OK. The following page will be displayed:

9 SERVICE CALL SETTING
PHONE NO. 0000000000000
MOBILE NO. 0000000000000
OK CONFIRM ADJUST

Press ▼ ▲ to scroll and set the phone number. The maximum length of the phone number is 13 digits, if the length of phone number is short than 12, please input ■, as shown below:

9 SERVICE CALL
PHONE NO. 33512345678■■■
MOBILE NO. 8613929145152■
OK CONFIRM ADJUST

The number displayed on the user interface is the phone number of your local dealer.

10.7.10 RESTORE FACTORY SETTINGS

The RESTORE FACTORY SETTING is used to restore all the parameters set in the user interface to the factory setting.

Go to MENU> FOR SERVICEMAN> 10.RESTORE FACTORY SETTINGS. Press OK. The following page will be displayed:

10 RESTORE FACTORY SETTINGS	
All the settings will come back to factory default. Do you want to restore factory settings?	
NO	YES
OK CONFIRM ▶◀	

Press ◀ ▶ to scroll the cursor to YES and press OK. The following page will be displayed:

10 RESTORE FACTORY SETTINGS	
Please wait...	
5%	

After a few seconds, all the parameters set in the user interface will be restored to factory settings.

10.7.11 TEST RUN

TEST RUN is used to check correct operation of the valves, air purge, circulation pump operation, cooling, heating and domestic water heating.

Go to MENU> FOR SERVICEMAN> 11.TEST RUN. Press OK. The following page will be displayed:

11 TEST RUN	
Active the settings and active the "TEST RUN"?	
NO	YES
OK CONFIRM ▶◀	

If YES is selected, the following pages will be displayed:

11 TEST RUN	
11.1 POINT CHECK	
11.2 AIR PURGE	
11.3 CIRCULATION PUMP RUNNING	
11.4 COOL MODE RUNNING	
11.5 HEAT MODE RUNNING	
OK ENTER ▶◀	

11 TEST RUN	
11.6 DHW MODE RUNNING	
OK ENTER ▶◀	

If POINT CHECK is selected, the following pages will be displayed:

11 TEST RUN(POINT CHECK) 1/2	
3-WAY VALVE	OFF
2-WAY VALVE	OFF
PUMP I	OFF
PUMP O	OFF
PUMP C	OFF
ON/OFF ON/OFF ▶◀	

11 TEST RUN(POINT CHECK) 2/2	
PUMPSOLAR	OFF
PUMPDHW	OFF
BACKUP HEATER	OFF
TANK HEATER	OFF
ON/OFF ON/OFF ▶◀	

Press ▼ ▲ to scroll to the components you want to check and press ON/OFF. For example, when 3-way valve is selected and ON/OFF is pressed, if the 3-way valve is open/close, then the operation of 3-way valve is normal, and so are other components.

⚠ CAUTION

Before the point check, make sure the tank and the water system is filled with water, and air is expelled, or it may cause the pump or backup heater burn out.

If you select AIR PURGE and OK is pressed, the following page will be displayed :

11 TEST RUN	
Test run is on. Air purge is on.	
OK CONFIRM	

When in air purge mode, the 3-way valve will open, the 2-way valve will close. 60s later the pump in the unit (PUMPI) will operate for 10min during which the flow switch will not work. After the pump stops, the 3-way valve will close and the 2-way valve will open. 60s later both the PUMPI and PUMPO will operate until the next command is received.

When CIRCULATION PUMP RUNNING is selected, the following page will be displayed:

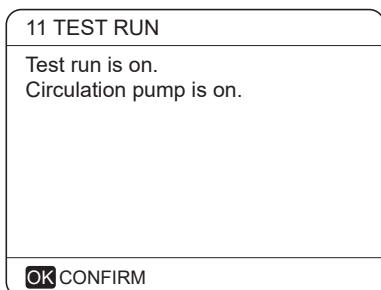

When circulation pump running is turned on, all running components will stop. 60 minutes later, the 3-way valve will open, the 2-way valve will close, 60 seconds later PUMPI will operate. 30s later, if the flow switch checked normal flow, PUMPI will operate for 3min, after the pump stops, the 3-way valve will close and the 2-way valve will open. 60s later the both PUMPI and PUMPO will operate, 2 mins later, the flow switch will check the water flow. If the flow switch closes for 15s, PUMPI and PUMPO will operate until the next command is received.

When the COOL MODE RUNNING is selected, the following page will be displayed:

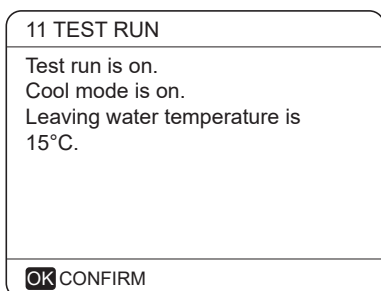

During COOL MODE test running, the default target outlet water temperature is 7°C. The unit will operate until the water temperature drops to a certain value or the next command is received.

When the HEAT MODE RUNNING is selected, the following page will be displayed:

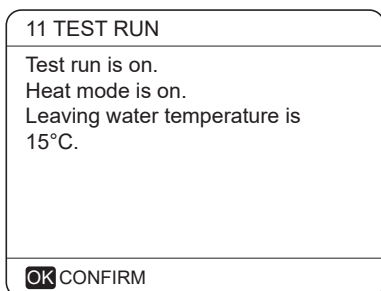

During HEAT MODE test running, the default target outlet water temperature is 35°C. The IBH (internal backup heater) will turn on after the compressor runs for 10 min. After the IBH runs for 3 minutes, the IBH will turn off, the heat pump will operate until the water temperature increase to a certain value or the next command is received.

When the DHW MODE RUNNING is selected, the following page will be displayed:

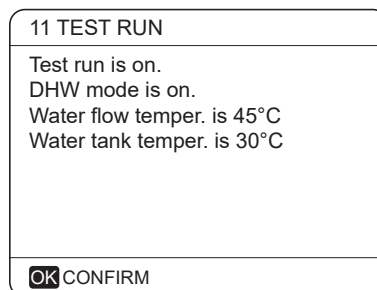

During DHW MODE test running, the default target temperature of the domestic water is 55°C. The TBH(tank boost heater) will turn on after the compressor runs for 10min. The TBH will turn off 3 minutes later, the heat pump will operate until the water temperature increase to a certain value or the next command is received.

During test run, all buttons except OK are invalid. If you want to turn off the test run, please press OK. For example ,when the unit is in air purge mode, after you press OK, the following page will be displayed:

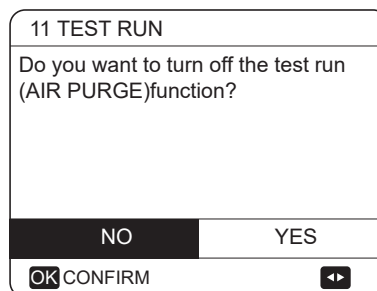

Press ◀ ▶ to scroll the cursor to YES and press OK. The test run will turn off.

10.7.12 SPECIAL FUNCTION

When it is in special function modes,the wired controller can not operate, the page do not return to the homepage, and the screen showed the page that special function runs, the wired controller do not locked.

NOTE

During special function operating other functions (WEEKLY SCHEDULE/TIMER , HOLIDAY AWAY, HOLIDAY HOME) can't be used.

Go to MENU> FOR SERVICEMAN> 12.SPECIAL FUNCTION.

Before floor heating, if a large amount of water remains on the floor, the floor may be warped or even rupture during floor heating operation, in order to protect the floor, floor drying is necessary, during which the temperature of the floor should be increased gradually.

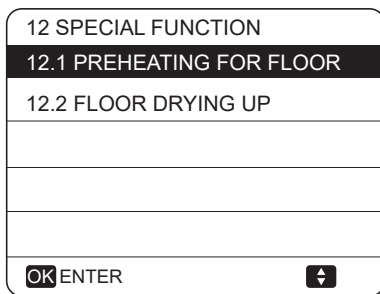
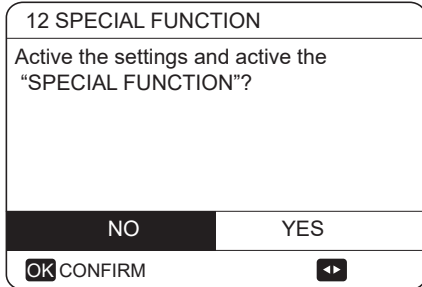

Press ▼ ▲ to scroll and press OK to enter.

During first operation of the unit, air may remain in the water system which can cause malfunctions during operation. It is necessary to run the air purge function to release the air (make sure the air purge valve is open).

If PREHEATING FOR FLOOR is selected, after press OK, the following page will be displayed:

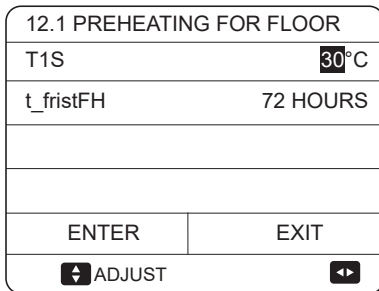

When the cursor is on OPERATE PREHEATING FOR FLOOR, Use ◀ ▶ to scroll to YES and press OK. The following page will be displayed:

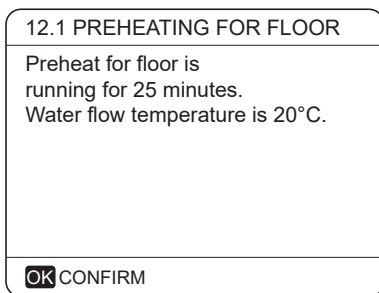

During preheating for floor, all the buttons except OK are invalid. If you want to turn off the preheating for floor, please press OK.

The following page will be displayed:

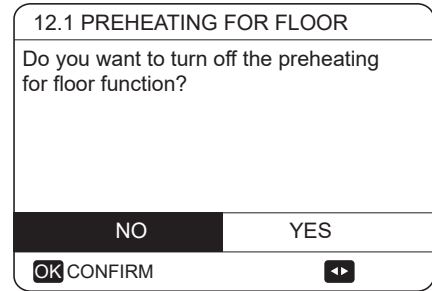

Use ◀ ▶ to scroll the cursor to YES and press OK, the preheating for floor will turn off.

The operation of the unit during preheating for floor described in the picture below:

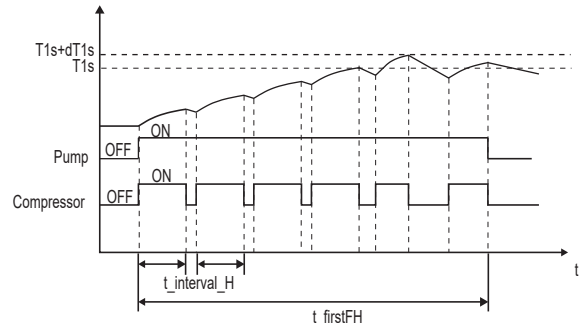

If FLOOR DRYING UP is selected, after press OK , the following pages will be displayed:

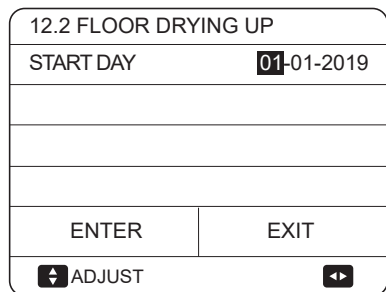
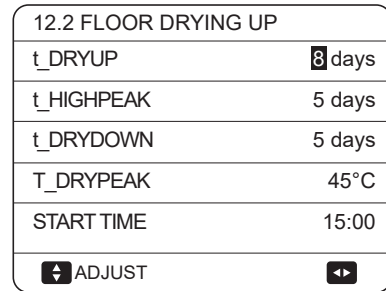

When the cursor is on OPERATE FLOOR DRYING, use ◀ ▶ to scroll to YES and press OK. The following page will be displayed:

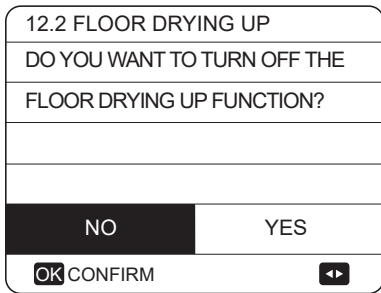

During floor drying, all the buttons except OK are invalid. When the heat pump malfunctions, the floor drying mode will turn off when the backup heater and additional heating source is unavailable. If you want to turn off floor drying up, please press OK. The following page will be displayed:

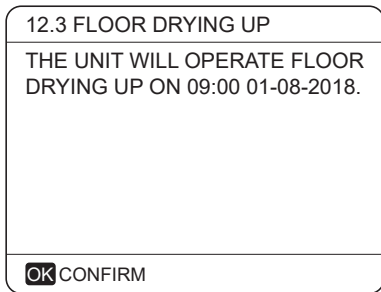

Use ◀ ▶ to scroll the cursor to YES and press OK. Floor drying will turn off.

The target outlet water temperature during floor drying up described in the picture below:

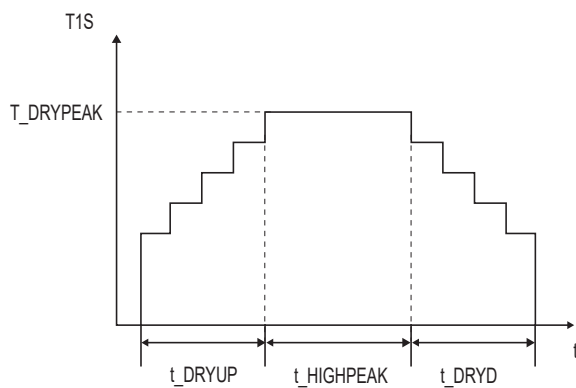

10.7.13 AUTO RESTART

The AUTO RESTART function is used to select whether the unit reapplies the user interface settings at the time when power returns after a power supply failure.

Go to MENU> FOR SERVICEMAN>13.AUTO RESTART

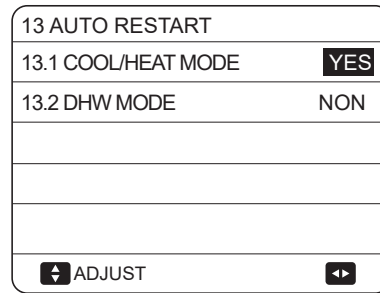

The AUTO RESTART function reapplies the user interface settings at the time of the power supply failure. If this function is disabled, when power returns after a power supply failure, the unit won't auto restart.

10.7.14 POWER INPUT LIMITATION

How to set the POWER INPUT LIMITATION

Go to MENU> FOR SERVICEMAN> 14.POWER INPUT LIMITATION

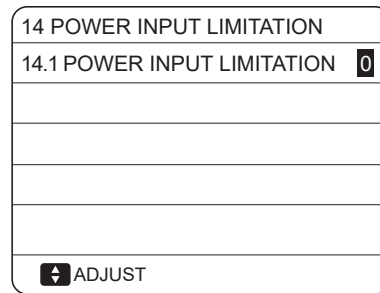

10.7.15 INPUT DEFINE

How to set the INPUT DEFINE

Go to MENU> FOR SERVICEMAN> 15.INPUT DEFINE

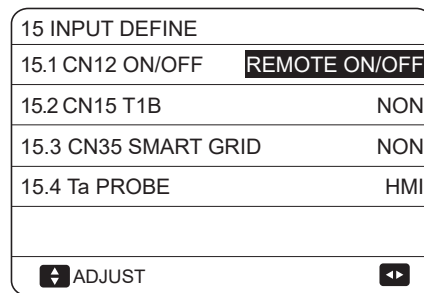

10.7.16 Setting parameters

The parameters related to this chapter are shown in the table below.

Order number	Code	State	Default	Minumum	Maximum	Setting interval	Unit
1.1	DHW MODE	Enable or disable the DHW mode:0=NON,1=YES	1	0	1	1	/
1.2	DISINFECT	Enable or disable the disinfect mode:0=NON,1=YES	1	0	1	1	/
1.3	DHW PRIORITY	Enable or disable the DHW priority mode:0=NON,1=YES	1	0	1	1	/
1.4	DHW PUMP	Enable or disable the DHW pump mode:0=NON,1=YES	0	0	1	1	/
1.5	DHW PRIORITY TIME SET	Enable or disable the DHW priority time set:0=NON,1=YES	0	0	1	1	/
1.6	dT5_ON	The temperature difference for starting the heat pump	5	2	10	1	°C
1.7	dT1S5	The correct value to adjust the output of the compressor.	10	5	40	1	°C
1.8	T4DHWMAX	The maximum ambient temperature that the heat pump can operate at for domestic water heating	43	35	43	1	°C
1.9	T4DHWMIN	The minimum ambient temperature that the heat pump can operate for domestic water heating	-10	-25	5	1	°C
1.10	t_INTERVAL_DHW	the start time interval of the compressor in DHW mode.	5	5	30	1	MIN
1.11	dT5_TBH_OFF	the temperature difference between T5 and T5S that turns the booster heater off.	5	0	10	1	°C
1.12	T4_TBH_ON	the highest outdoor temperature the TBH can operate.	5	-5	20	1	°C
1.13	t_TBH_DELAY	the time that the compressor has run before starting the booster heater	30	0	240	5	MIN
1.14	T5S_DI	the target temperature of water in the domestic hot water tank in the DISINFECT function.	65	60	70	1	°C
1.15	t_DI_HIGHTEMP.	the time that the highest temperature of water in the domestic hot water tank in the DISINFECT function will last	15	5	60	5	MIN
1.16	t_DI_MAX	the maximum time that disinfection will last	210	90	300	5	MIN
1.17	t_DHWHP_RESTRICT	he operation time for the space heating/cooling operation.	30	10	600	5	MIN
1.18	t_DHWHP_MAX	the maximum continuous working period of the heat pump in DHW PRIORITY mode.	90	10	600	5	MIN
1.19	PUMP RUNNING TIME	the certain time that the DHW pump will keep running for	5	5	120	1	MIN
1.20	DHW PUMP TIME RUN	Enable or disable the DHW pump run as timed and keeps running for PUMP RUNNING TIME:0=NON,1=YES	1	0	1	1	/
1.21	DHW PUMP DISINFECT	Enable or disable the DHW pump operate when the unit is in disinfect mode and $T5 \geq T5S_DI-2$:0=NON,1=YES	1	0	1	1	/
2.1	COOL MODE	Enable or disable the cooling mode:0=NON,1=YES	1	0	1	1	/
2.2	t_T4_FRESH_C	The refresh time of climate related curves for cooling mode	0.5	0.5	6	0.5	hours
2.3	T4CMAX	The highest ambient operation temperature for cooling mode	52	35	52	1	°C
2.4	T4CMIN	the lowest ambient operating temperature for cooling mode	10	-5	25	1	°C
2.5	dT1SC	the temperature difference for starting the heat pump(T1)	5	2	10	1	°C
2.6	dTSC	the temperature difference for starting the heat pump(Ta)	2	1	10	1	°C
2.7	t_INTERVAL_C	the start time interval of the compressor in cooling mode.	5	5	30	1	MIN
2.8	T1SETC1	The setting temperature 1 of climate related curves for cooling mode.	10	5	25	1	°C
2.9	T1SETC2	The setting temperature 2 of climate related curves for cooling mode.	16	5	25	1	°C
2.10	T4C1	The ambient temperature 1 of climate related curves for cooling mode.	35	-5	46	1	°C
2.11	T4C2	The ambient temperature 1 of climate related curves for cooling mode.	25	-5	46	1	°C
2.12	ZONE1 C-EMISSION	The type of zone1 end for cooling mode: 0=FCU(fan coil unit), 1=RAD.(radiator), 2=FLH(floor heating)	0	0	2	1	/
2.13	ZONE2 C-EMISSION	The type of zone2 end for cooling mode: 0=FCU(fan coil unit), 1=RAD.(radiator), 2=FLH(floor heating)	0	0	2	1	/

3.1	HEAT MODE	Enable or disable the heating mode	1	0	1	1	/
3.2	t_T4_FRESH_H	The refresh time of climate related curves for heating mode	0.5	0.5	6	0.5	hours
3.3	T4HMAX	The maximum ambient operating temperature for heating mode	25	20	35	1	°C
3.4	T4HMIN	The minimum ambient operating temperature for heating mode	-15	-25	15	1	°C
3.5	dT1SH	The temperature difference for starting the unit (T1)	5	2	10	1	°C
3.6	dTSH	The temperature difference for starting the unit (Ta)	2	1	10	1	°C
3.7	t_INTERVAL_H	The compressor start time interval	5	5	60	1	MIN
3.8	T1SETH1	The setting temperature 1 of climate related curves for heating mode	35	25	60	1	°C
3.9	T1SETH2	The setting temperature 2 of climate related curves for heating mode	28	25	60	1	°C
3.10	T4H1	The ambient temperature 1 of climate related curves for heating mode	-5	-25	35	1	°C
3.11	T4H2	The ambient temperature 2 of climate related curves for heating mode	7	-25	35	1	°C
3.12	ZONE1 H-EMISSION	The type of zone1 end for heating mode: 0=FCU(fan coil unit), 1=RAD.(radiator), 2=FLH(floor heating)	1	0	2	1	/
3.13	ZONE2 H-EMISSION	The type of zone2 end for heating mode: 0=FCU(fan coil unit), 1=RAD.(radiator), 2=FLH(floor heating)	2	0	2	1	/
3.14	t_DELAY_PUMP	the time that the compressor has run before starting the pump.	2	2	20	0.5	MIN
4.1	T4AUTOCMIN	The minimum operating ambient temperature for cooling in auto mode	25	20	29	1	°C
4.2	T4AUTOHMAX	The maximum operating ambient temperature for heating in auto mode	17	10	17	1	°C
5.1	WATER FLOW TEMP.	Enable or disable the WATER FLOW TEMP.:0=NON,1=YES	1	0	1	1	/
5.2	ROOM TEMP.	Enable or disable the ROOM TEMP.:0=NON,1=YES	0	0	1	1	/
5.3	DOUBLE ZONE	Enable or disable the ROOM THERMOSTAT DOUBLE ZONE:0=NON,1=YES	0	0	1	1	/
6.1	ROOM THERMOSTAT	The style of room thermostat: 0=NON,1=MODE SET,2=ONE ZONE,3=DOUBLE ZONE	0	0	3	1	/
7.1	dT1_IBH_ON	The temperature difference between T1S and T1 for starting the backup heater.	5	2	10	1	°C
7.2	t_IBH_DELAY	The time that the compressor has run before the first backup heater turns on	30	15	120	5	MIN
7.3	T4_IBH_ON	The ambient temperature for starting the backup heater	-5	-15	10	1	°C
7.4	dT1_AHS_ON	The temperature difference between T1S and T1B for turning the additional heating source on	5	2	10	1	°C
7.5	t_AHS_DELAY	The time that the compressor has run before starting the additional heating source	30	5	120	5	MIN
7.6	T4_AHS_ON	The ambient temperature for starting the additional heating source	-5	-15	10	1	°C
8.1	T1S_H.A_H	The target outlet water temperature for space heating when in holiday away mode	25	20	25	1	°C
8.2	T5S_H.A_DHW	The target outlet water temperature for domestic hot water heating when in holiday away mode	25	20	25	1	°C
12.1	PREHEATING FOR FLOOR T1S	The setting temperature of outlet water during first preheating for floor	25	25	35	1	°C
12.3	t_FIRSTFH	The time last for preheating floor	72	48	96	12	HOUR
12.4	t_DRYUP	The day for warming up during floor drying up	8	4	15	1	DAY
12.5	t_HIGHPEAK	The continue days in high temperature during floor drying up	5	3	7	1	DAY
12.6	t_DRYD	The day of dropping temperature during floor drying up	5	4	15	1	DAY

12.7	T_DRYPEAK	The target peak temperature of water flow during floor drying up	45	30	55	1	°C
12.8	START TIME	The start time of floor drying up	Hour: the present time (not on the hour +1, on the hour +2) Minute:00	0:00	23:30	1/30	h/min
12.9	START DATE	The start date of floor drying up	The present date	1/1/2000	31/12/2099	2001-1-1	d/m/y
13.1	AUTO RESTART COOL/HEAT MODE	Enable or disable the auto restart cooling/heating mode. 0=NON, 1=YES	1	0	1	1	/
13.2	AUTO RESTART DHW MODE	Enable or disable the auto restart DHW mode. 0=NON, 1=YES	1	0	1	1	/
14.1	POWER INPUT LIMITATION	The type of power input limitation, 0=NON, 1~8=TYPE 1~8	0	0	8	1	/
15.1	CN12 ON/OFF	Define the CN12 port, 0= REMOTE ON/OFF, 1= TBH ON/OFF	0	0	1	1	/
15.2	CN15 T1B	Enable or disable the T1B PROBE. 0=NON; 1=YES	0	0	1	1	/
15.3	CN35 SMART GRID	Enable or disable the SMART GRID. 0=NON; 1=YES	0	0	1	1	/
15.4	Ta PROBE	Choose the sensor of Ta. 0=HMI Ta on wired controller; 1=IDU Ta connected on the mainboard of indoor unit	0	0	1	1	/

10.7.17 Description of terms

The terms related to this unit are shown in the table below.

Parameter	illustration
T1	Outlet water temperature of backup heater (or additional heating source)
T1B	Outlet water temperature of zone 2
T1S	Target outlet water temperature
T2	Temperature of refrigerant at outlet /inlet of plate heat exchanger when in heat mode/cool mode
T2B	Temperature of refrigerant at let outlet /inlet of plate heat exchanger when in heat mode/cool mode
T3	Temperature of tube at outlet/inlet of condenser when in cool/heat mode
T4	Ambient temperature
T5	Temperature of domestic hot water
Th	Suction temperature
Tp	Discharge temperature
TW_in	Inlet water temperature of plate heat exchanger
TW_out	Outlet water temperature of plate heat exchanger
AHS	Additional heating source
IBH1	The first backup heater
IBH 2	The second backup heater
TBH	Backup heater in the domestic hot water tank
Pe	Evaporate/condense pressure in cool/heat mode

11 TEST RUN AND FINAL CHECKS

The installer is obliged to verify correct operation of unit after installation.

11.1 Final checks

Before switching on the unit, read following recommendations:

- When the complete installation and all necessary settings have been carried out, close all front panels of the unit and refit the unit cover.
- The service panel of the switch box may only be opened by a licensed electrician for

NOTE

That during the first running period of the unit, required power input may be higher than stated on the nameplate of the unit. This phenomenon originates from the compressor that needs elapse of a 50 hours run in period before reaching smooth operation and stable power consumption.

11.2 Test run operation (manually)

If required, the installer can perform a manual test run operation at any time to check correct operation of air purge, heating, cooling and domestic water heating, refer to 10.7 Field settings/test run.

12 MAINTENANCE AND SERVICE

In order to ensure optimal availability of the unit, a number of checks and inspections on the unit and the field wiring have to be carried out at regular intervals.

This maintenance needs to be carried out by your local technician.

In order to ensure optimal availability of the unit, a number of checks and inspections on the unit and the field wiring have to be carried out at regular intervals.

This maintenance has to be carried out by your local technician.

DANGER

ELECTRIC SHOCK

- Before carrying out any maintenance or repairing activity, must switch off the power supply on the supply panel.
- Do not touch any live part for 10 minutes after the power supply is turned off.
- The crank heater of compressor may operate even in standby.
- Please note that some sections of the electric component box are hot.
- Forbid touch any conductive parts.
- Forbid rinse the unit. It may cause electric shock or fire.
- Forbid leave the unit unattended when service panel is removed.

The following checks must be performed at least once a year by qualified person.

- **Water pressure**
Check the water pressure, if it is below 1 bar, fill water to the system.
- **Water filter**
Clean the water filter.
- **Water pressure relief valve**
Check for correct operation of the pressure relief valve by turning the black knob on the valve counter-clockwise:

-If you do not hear a clacking sound, contact your local dealer.

-In case the water keeps running out of the unit, close both the water inlet and outlet shut-off valves first and then contact your local dealer.
- **Pressure relief valve hose**
Check that the pressure relief valve hose is positioned appropriately to drain the water.
- **Backup heater vessel insulation cover**
Check that the backup heater insulation cover is fastened tightly around the backup heater vessel.
- **Domestic hot water tank pressure relief valve (field supply)** Applies only to installations with a domestic hot water tank. Check for correct operation of the pressure relief valve on the domestic hot water tank.
- **Domestic hot water tank booster heater**
Applies only to installations with a domestic hot water tank. It is advisable to remove lime buildup on the booster heater to extend its life span, especially in regions with hard water. To do so, drain the domestic hot water tank, remove the booster heater from the domestic hot water tank and immerse in a bucket (or similar) with lime-removing product for 24 hours.
- **Unit switch box**

-Carry out a thorough visual inspection of the switch box and look for obvious defects such as loose connections or defective wiring.

-Check for correct operation of contactors with an ohm meter. All contacts of these contactors must be in open position.

Use of glycol (Refer to 9.3 Water pipework Caution: "Use of glycol") Document the glycol concentration and the pH-value in the system at least once a year.

-A PH-value below 8.0 indicates that a significant portion of the inhibitor has been depleted and that more inhibitor needs to be added.

-When the PH-value is below 7.0 then oxidation of the glycol occurred, the system should be drained and flushed thoroughly before severe damage occurs.

Make sure that the disposal of the glycol solution is done in accordance with relevant local laws and regulations.

13 TROUBLE SHOOTING

This section provides useful information for diagnosing and correcting certain troubles which may occur in the unit.

This troubleshooting and related corrective actions may only be carried out by your local technician.

13.1 General guidelines

Before starting the troubleshooting procedure, carry out a thorough visual inspection of the unit and look for obvious defects such as loose connections or defective wiring.

WARNING

When carrying out an inspection on the switch box of the unit, always make sure that the main switch of the unit is switched off.

When a safety device was activated, stop the unit and find out why the safety device was activated before resetting it. Under no circumstances can safety devices be bridged or changed to a value other than the factory setting. If the cause of the problem cannot be found, call your local dealer.

If the pressure relief valve is not working correctly and is to be replaced, always reconnect the flexible hose attached to the pressure relief valve to avoid water dripping out of the unit!

NOTE

For problems related to the optional solar kit for domestic water heating, refer to the troubleshooting in the Installation & Owner's manual for that kit.

13.2 General symptoms

Symptom 1: The unit is turned on but the unit is not heating or cooling as expected

POSSIBLE CAUSES	CORRECTIVE ACTION
The temperature setting is not correct.	Check the controller set point. T4HMAX, T4HMIN in heat mode. T4CMAX, T4CMIN in cool mode. T4DHWMAX, T4DHWMIN in DHW mode.
The water flow is too low.	<ul style="list-style-type: none"> • Check that all shut off valves of the water circuit are completely open. • Check if the water filter needs cleaning. • Make sure there is no air in the system (purge air). • Check on the manometer that there is sufficient water pressure. The water pressure must be >1 bar (water is cold). • Make sure that the expansion vessel is not broken. • Check that the resistance in the water circuit is not too high for the pump.
The water volume in the installation is too low.	Make sure that the water volume in the installation is above the minimum required value (refer to "9.3 water piping/Checking the water volume and expansion vessel pre-pressure").

Symptom 2: The unit is turned on but the compressor is not starting (space heating or domestic water heating)

POSSIBLE CAUSES	CORRECTIVE ACTION
The unit must start up out of its operation range (the water temperature is too low).	<p>In case of low water temperature, the system utilizes the backup heater to reach the minimum water temperature first (12°C).</p> <ul style="list-style-type: none"> • Check that the backup heater power supply is correct. • Check that the backup heater thermal fuse is closed. • Check that the backup heater thermal protector is not activated. • Check that the backup heater contactors are not broken.

Symptom 3: Pump is making noise (cavitation)

POSSIBLE CAUSES	CORRECTIVE ACTION
There is air in the system.	Purge air.
Water pressure at pump inlet is too low.	<ul style="list-style-type: none"> • Check on the manometer that there is sufficient water pressure. The water pressure must be > 1 bar (water is cold). • Check that the manometer is not broken. • Check that the expansion vessel is not broken. • Check that the setting of the pre- pressure of the expansion vessel is correct (refer to "9.3 water piping/Checking the water volume and expansion vessel pre-pressure").

Symptom 4: The water pressure relief valve opens

POSSIBLE CAUSES	CORRECTIVE ACTION
The expansion vessel is broken.	Replace the expansion vessel.
The filling water pressure in the installation is higher than 0.3MPa.	Make sure that the filling water pressure in the installation is about 0.15~0.20MPa (refer to "9.3 water piping/Checking the water volume and expansion vessel pre-pressure").

Symptom 5: The water pressure relief valve leaks

POSSIBLE CAUSES	CORRECTIVE ACTION
Dirt is blocking the water pressure relief valve outlet.	<p>Check for correct operation of the pressure relief valve by turning the red knob on the valve counter clockwise:</p> <ul style="list-style-type: none"> • If you do not hear a clacking sound, contact your local dealer. • In case the water keeps running out of the unit, close both the water inlet and outlet shut-off valves first and then contact your local dealer.

Symptom 6: Space heating capacity shortage at low outdoor temperatures

POSSIBLE CAUSES	CORRECTIVE ACTION
Backup heater operation is not activated.	<p>Check that the "OTHER HEATING SOURCE/ BACKUP HEATER" is enabled, see "10.7 Field settings" Check whether or not the thermal protector of the backup heater has been activated (refer to "Controls parts for backup heater (IBH) "). Check if booster heater is running, the backup heater and booster heater can't operate simultaneously.</p>
Too much heat pump capacity is used for heating domestic hot water (applies only to installations with a domestic hot water tank).	<p>Check that the "t_DHWHP_MAX" and "t_DHWHP_RESTRICT" are configured appropriately:</p> <ul style="list-style-type: none"> • Make sure that the "DHW PRIORITY" in the user interface is disabled. • Enable the "T4_TBH_ON" in the user interface/FOR SERVICEMAN to activate the booster heater for domestic water heating.

Symptom 7: Heat mode can't change to DHW mode immediately

POSSIBLE CAUSES	CORRECTIVE ACTION
Volume of tank is too small and the location of water temperature probe not high enough	<ul style="list-style-type: none"> • Set "dT1S5" to 20°C, and set "t_DHWHP_RESTRICT" to minimum value. • Set dT1SH to 2°C. • Enable TBH, and TBH should be controlled by the outdoor unit. • If AHS(boiler) is available, turn boiler on first, if requirement for turn heat pump on is fulfilled, the heat pump will turn on. • If both TBH and AHS are not available, try to change the position of T5 probe (refer to 2 General information/Domestic hot water tank).

Symptom 8: DHW mode can't change to Heat mode immediately

POSSIBLE CAUSES	CORRECTIVE ACTION
Heat exchanger for space heating not big enough	<ul style="list-style-type: none"> Set "t_DHWHP_MAX" to minimum value, the suggested value is 60min. If circulating pump out of unit is not controlled by unit, try to connect it to the unit. Add 3-way valve at the inlet of fan coil to ensure enough water flow.
Space heating load is small	Normal , no need for heating
Disinfect function is enabled but without TBH	<ul style="list-style-type: none"> Disable disinfect function add TBH or AHS for DHW mode

Symptom 9: DHW mode heat pump stop work but setpoint not reached, space heating require heat but unit stay in DHW mode

POSSIBLE CAUSES	CORRECTIVE ACTION
Surface of coil in the tank not large enough	The same solution for Symptom 7
TBH or AHS not available	Heat pump will stay in DHW mode until "t_DHWHP_MAX" reached or setpoint is reached. Add TBH or AHS for DHW mode, TBH and AHS should be controlled by the unit.

13.3 Operation parameter

This menu is for installer or service engineer reviewing the operation parameter.

- At home page, go to "MENU">"OPERATION PARAMETER".
- Press "OK". There are six pages for the operating parameter as following. Press "▼", "▲" to scroll.

OPERATION PARAMETER	1/6
OPERATE MODE	COOL
CURRENT	12A
COMPRESSOR FREQUENCY	24Hz
COMP.RUN TIME1	54MIN
COMP.RUN TIME2	65MIN
COMP.RUN TIME3	10MIN
⬇	

OPERATION PARAMETER	2/6
COMP. RUN TIME4	1000HOUR
EXPANSION VALVE	200P
FAN SPEED	600R/MIN
IDU TARGET FREQUENCY	46Hz
FREQUENCY LIMITED TYPE	5
T1 LEAVING WATER TEMP.	35°C
⬇	

OPERATION PARAMETER	3/6
T1B CIRCUIT2 WATER TEMP.	35°C
T2 PLATE F-OUT TEMP.	35°C
T2B PLATE F-IN TEMP.	35°C
T3 OUTDOOR EXCHANGE TEMP.	5°C
T4 OUTDOOR AIR TEMP.	5°C
T5 WATER TANK TEMP.	53°C
⬇	

OPERATION PARAMETER	4/6
Ta ROOM TEMP.	25°C
Th COMP. SUCTION TEMP.	5°C
Tp COMP. DISCHARGE TEMP.	75°C
TW_O PLATE W-OUTLET TEMP.	35°C
TW_I PLATE W-INLET TEMP.	30°C
P1 COMP.PRESSURE	2300kPa
⬇	

OPERATION PARAMETER	5/6
T1S' C1 CLIMATE CURVE TEMP.	35°C
T1S2' C2 CLIMATE CURVE TEMP.	35°C
TF MODULE TEMP.	55°C
SUPPLY VOLTAGE	230V
POWER CONSUM.	1000kWh
DC GENERATRIX VOLTAGE	420V
⬇	

OPERATION PARAMETER	6/6
DC GENERATRIX CURRENT	18A
WATER FLOW	1.72M3/H
HEAT PUMP CAPACITY	11.52kW
HMI SOFTWARE	XX-XX-XXXXXXXX
IDU SOFTWARE	XX-XX-XXXXXXXX
ODU SOFTWARE	XX-XX-XXXXXXXX
⬇	

NOTE

The power consumption parameter is preparatory. some parameter is not be activated in the system, the parameter will show "--"

The heat pump capacity is for reference only, not used to judge the ability of the unit. The accuracy of sensor is $\pm 1^\circ\text{C}$. The flow rates parameters are calculated according to the pump running parameters, the deviation is different at different flow rates, the maximum of deviation is 25%.

13.4 Error codes

When a safety device is activated, an error code will be displayed on the user interface.

A list of all errors and corrective actions can be found in the table below.

Reset the safety by turning the unit OFF and back ON.

In case this procedure for resetting the safety is not successful, contact your local dealer.

ERROR CODE	MALFUNCTION OR PROTECTION	FAILURE CAUSE AND CORRECTIVE ACTION
<i>E0</i>	Flow switch error (E8 displayed 3 times)	<ol style="list-style-type: none"> 1.The wire circuit is short connected or open. Reconnect the wire correctly. 2.Water flow rate is too low. 3. Water flow switch is failed, switch is open or close continuously, change the water flow switch.
<i>E1</i>	Phase sequence fault(only for threephase unit)	<ol style="list-style-type: none"> 1.Check the power supply cables should be connected stable, to avoid phase loss. 2.Check the power supply cables sequence, change any two cables sequence of the three power supply cables.
<i>E2</i>	Communication error between user interface and main control board of hydraulic module	<ol style="list-style-type: none"> 1.wire doesn't connect between wired controller and unit. connect the wire. 2.Communication wire sequence is not right. Reconnect the wire in the right sequence. 3. Whether there is a high magnetic field or high power interfere, such as lifts, large power transformers, etc.. <p>To add a barrier to protect the unit or to move the unit to the other place.</p>
<i>E3</i>	The backup heater exchanger outlet water temperature sensor (T1) error	<ol style="list-style-type: none"> 1. The T1 sensor connector is loosen. Reconnect it. 2.The T1 sensor connector is wet or there is water in. remove the water, make the connector dry. Add waterproof adhesive. 3.The T1 sensor failure, change a new sensor.
<i>E4</i>	The domestic hot water temperature sensor (T5) error.	<ol style="list-style-type: none"> 1.The T5 sensor connector is loosen. Reconnect it. 2.The T5 sensor connector is wet or there is water in. remove the water, make the connector dry. Add waterproof adhesive 3.The T5 sensor failure, change a new sensor.
<i>E5</i>	The condenser outlet refrigerant temperature sensor (T3)error.	<ol style="list-style-type: none"> 1. The T3 sensor connector is loosen. Reconnect it. 2.The T3 sensor connector is wet or there is water in. remove the water, make the connector dry. Add waterproof adhesive 3. The T3 sensor failure, change a new sensor.
<i>E6</i>	The ambient temperature sensor (T4) error.	<ol style="list-style-type: none"> 1. The T4 sensor connector is loosen. Reconnect it. 2.The T4 sensor connector is wet or there is water in. remove the water, make the connector dry. Add waterproof adhesive 3. The T4 sensor failure, change a new sensor.

ERROR CODE	MALFUNCTION OR PROTECTION	FAILURE CAUSE AND CORRECTIVE ACTION
<i>EB</i>	Water flow failure	<p>Check that all shut off valves of the water circuit are completely open.</p> <ol style="list-style-type: none"> 1. Check if the water filter needs cleaning. 2. Refer to "9.4 Charging water" 3. Make sure there is no air in the system(purge air). 4. Check on the manometer that there is sufficient water pressure. The water pressure must be >1 bar. 5. Check that the pump speed setting is on the highest speed. 6. Make sure that the expansion vessel is not broken. 7. Check that the resistance in the water circuit is not too high for the pump (refer to "Setting the pump speed"). 8. If this error occurs at defrost operation (during space heating or domestic water heating), make sure that the backup heater power supply is wired correctly and that fuses are not blown. 9. Check that the pump fuse and PCB fuse are not blown.
<i>E9</i>	Suction temperature sensor(Th) error	<ol style="list-style-type: none"> 1. The Th sensor connector is loosen. Re connect it. 2.The Th sensor connector is wet or there is water in. remove the water, make the connector dry. Add waterproof adhesive 3. The Th sensor failure, change a new sensor.
<i>EA</i>	Discharge temperature sensor(Tp) error	<ol style="list-style-type: none"> 1. The Tp sensor connector is loosen. Re connect it. 2.The Tp sensor connector is wet or there is water in. remove the water, make the connector dry. Add waterproof adhesive 3. The Tp sensor failure, change a new sensor.
<i>Ed</i>	inlet water temperature sensor(Tw_in) error	<ol style="list-style-type: none"> 1. The Tw_in sensor connector is loosen. Re connect it. 2.The Tw_in sensor connector is wet or there is water in. remove the water, make the connector dry. Add waterproof adhesive 3. The Tw_in sensor failure, change a new sensor.
<i>EE</i>	The main control board of hydraulic module EEPROM failure	<ol style="list-style-type: none"> 1. The EEPROM parameter is error, rewrite the EEPROM data. 2. EEPROM chip part is broken, change a new EEPROM chip part. 3. main control board of hydraulic module is broken, change a new PCB.
<i>HO</i>	Communication error between main control board PCB B and main control board of hydraulic module	<ol style="list-style-type: none"> 1.wire doesn't connect between main control board PCB B and main control board of hydraulic module. connect the wire. 2.Communication wire sequence is not right. Reconnect the wire in the right sequence. 3. Whether there is a high magnetic field or high power interfere, such as lifts, large power transformers, etc.. To add a barrier to protect the unit or to move the unit to the other place.

ERROR CODE	MALFUNCTION OR PROTECTION	FAILURE CAUSE AND CORRECTIVE ACTION
<i>H1</i>	Communication error between inverter module PCB A and main control board PCB B	<ol style="list-style-type: none"> Whether there is power connected to the PCB and driven board. Check the PCB indicator light is on or off. If Light is off, reconnect the power supply wire. If light is on, check the wire connection between the main PCB and driven PCB, if the wire loosen or broken, reconnect the wire or change a new wire. Replace a new main PCB and driven board in turn.
<i>H2</i>	The plate heat exchanger refrigerant inlet(liquid pipe) temperature sensor(T2) error.	<ol style="list-style-type: none"> The T2 sensor connector is loosen. Re connect it. The T2 sensor connector is wet or there is water in. remove the water, make the connector dry. Add waterproof adhesive The T2 sensor failure, change a new sensor.
<i>H3</i>	The plate heat exchanger refrigerant outlet(gas pipe) temperature sensor (T2B) error.	<ol style="list-style-type: none"> The T2B sensor connector is loosen. Re connect it. The T2B sensor connector is wet or there is water in. remove the water, make the connector dry. Add waterproof adhesive The T2B sensor failure, change a new sensor.
<i>H4</i>	Three times P6 protect	Same to P6
<i>H5</i>	The indoor temperature sensor(Ta) error	<ol style="list-style-type: none"> The Ta sensor is in the interface; The Ta sensor failure, change a new sensor or change a new interface.
<i>H6</i>	The DC fan failure	<ol style="list-style-type: none"> Strong wind or typhoon below toward to the fan, to make the fan running in the opposite direction. Change the unit direction or make shelter to avoid typhoon below to the fan. fan motor is broken, change a new fan motor.
<i>H7</i>	Main circuit voltage failure	<ol style="list-style-type: none"> Whether the power supply input is in the available range. Power off and power on for several times rapidly in short time. Remain the unit power off for more than 3 minutes than power on. the circuit defect part of Main control board is defective. Replace a new Main PCB.
<i>H8</i>	Pressure sensor failure	<ol style="list-style-type: none"> Pressure sensor connector is loosen, reconnect it. Pressure sensor failure. change a new sensor.
<i>H9</i>	The system outlet water temperature sensor T1B failure.	<ol style="list-style-type: none"> The T1B sensor connector is loosen. Reconnect it. The T1B sensor connector is wet or there is water in. remove the water, make the connector dry. add waterproof adhesive The T1B sensor failure, change a new sensor.
<i>HA</i>	The plate heat exchanger water outlet temperature sensor (TW_out) error.	<ol style="list-style-type: none"> The TW_out sensor connector is loosen. Reconnect it. The TW_out sensor connector is wet or there is water in. remove the water, make the connector dry. add waterproof adhesive The TW_out sensor failure, change a new sensor.

ERROR CODE	MALFUNCTION OR PROTECTION	FAILURE CAUSE AND CORRECTIVE ACTION
<i>HE</i>	The condenser refrigerant outlet temperature is too high in heating mode for more than 10 minutes.	The outside ambient temperature is too high(higher than 30°C, the unit still operate heat mode. close the heat mode when the ambient temperature is higher than 30°C.
<i>HF</i>	The main control board PCB B EEPROM failure	<ol style="list-style-type: none"> 1. The EEPROM parameter is error, rewrite the EEPROM data. 2. EEPROM chip part is broken, change a new EEPROM chip part. 3. Main PCB is broken, change a new PCB.
<i>HH</i>	H6 displayed 10 times in 2 hours	Refer to H6
<i>HL</i>	PFC module fault	Contact your local dealer
<i>HP</i>	Low pressure protection (Pe<0.6) occurred 3 times in an hour	Refer to P0
<i>P0</i>	Low pressure protection	<ol style="list-style-type: none"> 1. System is lack of refrigerant volume. Charge the refrigerant in right volume. 2. When at heating mode or heat water mode, Heat exchanger is dirty or something is block on the surface. Clean the heat exchanger or remove the obstruction. 3. The water flow is low in cooling mode. 4. Electrical expansion valve locked or winding connector is loosen. Tap-tap the valve body and plug in/ plug off the connector for several times to make sure the valve is working correctly. And install the winding in the right location.
<i>P1</i>	High pressure protection	<p>Heating mode, DHW mode:</p> <ol style="list-style-type: none"> 1. The water flow is low; water temp is high, whether there is air in the water system. Release the air. 2. Water pressure is lower than 0.1Mpa, charge the water to let the pressure in the range of 0.15~0.2Mpa. 3. Over charge the refrigerant volume. Recharge the refrigerant in right volume. 4. Electrical expansion valve locked or winding connector is loosen. Tap-tap the valve body and plug in/ plug off the connector for several times to make sure the valve is working correctly. And install the winding in the right location <p>DHW mode: Water tank heat exchanger is smaller than the required 1.7m2.(10-16kW unit)or 1.4m2(5-9kW unit) Cooling mode:</p> <ol style="list-style-type: none"> 1. Heat exchanger cover is not removed. Remove it. 2. Heat exchanger is dirty or something is block on the surface. Clean the heat exchanger or remove the obstruction.
<i>P3</i>	Compressor overcurrent protection.	<ol style="list-style-type: none"> 1. The same reason to P1. 2. Power supply voltage of the unit is low, increase the power voltage to the required range.

ERROR CODE	MALFUNCTION OR PROTECTION	FAILURE CAUSE AND CORRECTIVE ACTION
<i>P4</i>	High discharge temperature protection.	<ol style="list-style-type: none"> 1. The same reason to P1. 2. System is lack of refrigerant volume. Charge the refrigerant in right volume. 3. TW_out temp sensor is loosen Reconnect it.. 4. T1 temp sensor is loosen. Reconnect it. 5. T5 temp sensor is loosen. Reconnect it.
<i>P5</i>	High Temperature difference protection between water inlet and water outlet of the plate heat exchanger.	<ol style="list-style-type: none"> 1. Check that all shut off valves of the water circuit are completely open. 2. Check if the water filter needs cleaning. 3. Refer to "9.4 Charging water" 4. Make sure there is no air in the system (purge air). 5. Check on the manometer that there is sufficient water pressure. The water pressure must be >1 bar(water is cold). 6. Check that the pump speed setting is on the highest speed. 7. Make sure that the expansion vessel is not broken. 8. Check that the resistance in the water circuit is not too high for the pump. (refer to "10.6 Setting the pump speed").
<i>P6</i>	Module protection	<ol style="list-style-type: none"> 1. Power supply voltage of the unit is low, increase the power voltage to the required range. 2. The space between the units is too narrow for heat exchange. Increase the space between the units. 3. Heat exchanger is dirty or something is block on the surface. Clean the heat exchanger or remove the obstruction. 4. Fan is not running. Fan motor or fan is broken, Change a new fan or fan motor. 5. Over charge the refrigerant volume. Recharge the refrigerant in right volume. 6. Water flow rate is low, there is air in system, or pump head is not enough. Release the air and reselect the pump. 7. Water outlet temp sensor is loosen or broken, reconnect it or change a new one. 8. Water tank heat exchanger is smaller than the required 1.7m2.(1016kW unit)or 1.4m2(5-9kW unit). 9. Module wires or screws are loosen. Reconnect wires and screws. The Thermal Conductive Adhesive is dry or drop. Add some thermal conductive adhesive. 10. The wire connection is loosen or drop. Reconnect the wire. 11. Drive board is defective, replace a new one. 12. If already confirm the control system has no problem, then compressor is defective, replace a new compressor.
<i>P9</i>	DC fan motor protect	Contact your local dealer

ERROR CODE	MALFUNCTION OR PROTECTION	FAILURE CAUSE AND CORRECTIVE ACTION
<i>Pd</i>	High temperature protection of refrigerant outlet temp of condenser.	<ol style="list-style-type: none"> 1. Heat exchanger cover is not removed. Remove it. 2. Heat exchanger is dirty or something is block on the surface. Clean the heat exchanger or remove the obstruction. 3. There is no enough space around the unit for heat exchanging. 4. fan motor is broken, replace a new one.
<i>Pb</i>	Anti-freeze mode protection	Unit will return to the normal operation automatically.
<i>PP</i>	Water inlet temperature is higher than water outlet in heating mode	<ol style="list-style-type: none"> 1.The water inlet/outlet sensor wire connector is loosen. Reconnect it. 2.The water inlet/outlet (TW_in /TW_out) sensor is broken, Change a new sensor. 3. Four-way valve is blocked. Restart the unit again to let the valve change the direction. 4.Four-way valve is broken, change a new valve.
<i>F1</i>	DC generatrix voltage is too low	<ol style="list-style-type: none"> 1. Check the power supply. 2. If the power supply is OK,and check if LED light is OK, check the voltage PN, if it is 380V, the problem usually comes from the main board. And if the light is OFF, disconnect the power, check the IGBT, check those dioxides, if the voltage is not correct, the inverter board is damaged, change it. 3. And if those IGBT are OK, which means the inverter board is OK, power form rectifier bridge is not correct, check the bridge. (Same method as IGBT, disconnect the power, check those dioxides are damaged or not). 4. Usually if F1 exist when compressor start, the possible reason is main board. If F1 exist when fan start, it may be because of inverter board.

14 TECHNICAL SPECIFICATIONS

14.1 General

	1-phase	3-phase	1-phase
	12/14/16 kW	12/14/16 kW	5/7/9 kW
Nominal capacity	Refer to the Technical Data		
Dimensions HxWxD	1414×1404×405mm	1414×1404×405mm	945×1210×402mm
Weight (without backup heater)			
Net weight	158kg	172kg	92kg
Gross weight	178kg	193kg	111kg
Weight (backup heater have be intergrated in the unit)			
Net weight	163kg	177kg	/
Gross weight	183kg	198kg	/
Connections			
water inlet/outlet	G5/4"BSP	G5/4"BSP	G1"BSP
Water drain	hose nipple		
Expansion vessel			
volume	5L	5L	2L
Maximum working pressure (MWP)	8 bar	8 bar	8 bar
Pump			
Type	water cooled	water cooled	water cooled
No. of speed	3	3	3
Internal water volume	3.2L	3.2L	2.0L
Pressure relief valve water circuit	3 bar	3 bar	3 bar
Operation range - water side			
heating	+12~+60°C	+12~+60°C	+12~+60°C
cooling	+5~+25°C	+5~+25°C	+5~+25°C
Operation range - air side			
heating	-25~35°C		
cooling	-5~46°C		-5~43°C
domestic hot water by heat pump	-25~43°C		

14.2 Electrical specifications

	1-phase 5/7/9/12/14/16	3-phase 12/14/16
Standard unit (power supply via unit)		
Power Supply	220-240V~ 50Hz	380-415V 3N~ 50Hz
Nominal Running Current	See "9.7.4 Specifications of standard wiring components"	
Backup heater		
Power Supply	See "9.7.5 Connection of the backup heater power supply"	
Nominal Running Current		

15 REPLACEMENT OF SAFETY VALVE (Only for 12~16kW units)

Visual inspection is needed after that period, maintenance people should check the appearance of the valve body and the operating environment. If the valve body is not obvious corrosion, cracks, dirt, damage, then the valve can be used continually. Otherwise, please contact your supplier for spare part.

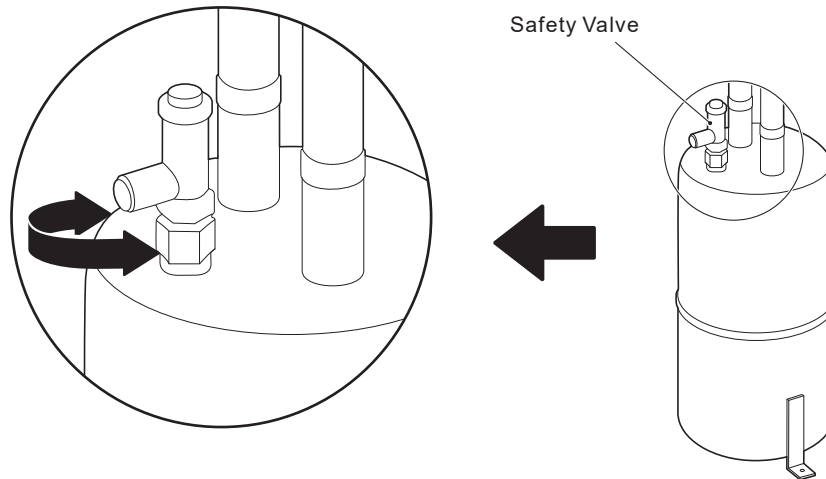

Replace the safety valve as follows (Suitable for type with safety valve):

- 1) Reclaim the refrigerant completely in the system. Doing so requires professional staff and equipment;
- 2) Note to protect the tank coating. Avoid damage to coating from external force or high temperature when removing and installing the safety valve;
- 3) Heat the sealant to screw off the safety valve. Note to protect the area where the screwing tool meets the tank body and avoid damages to the tank coating;
- 4) If tank coating is damaged, repaint the damaged area.

16 INFORMATION SERVICING

1) Checks to the area

Prior to beginning work on systems containing flammable refrigerants, safety checks are necessary to ensure that the risk of ignition is minimised. For repair to the refrigerating system, the following precautions shall be complied with prior to conducting work on the system.

2) Work procedure

Works shall be undertaken under a controlled procedure so as to minimise the risk of a flammable gas or vapour being present while the work is being performed.

3) General work area

All maintenance staff and others working in the local area shall be instructed on the nature of work being carried out. Work in confined spaces shall be avoided. The area around the work space shall be sectioned off. Ensure that the conditions within the area have been made safe by control of flammable material.

4) Checking for presence of refrigerant

The area shall be checked with an appropriate refrigerant detector prior to and during work, to ensure the technician is aware of potentially flammable atmospheres. Ensure that the leak detection equipment being used is suitable for use with flammable refrigerants, i.e. no sparking, adequately sealed or intrinsically safe.

5) Presence of fire extinguisher

If any hot work is to be conducted on the refrigeration equipment or any associated parts, appropriate fire extinguishing equipment shall be available to hand. Have a dry power or CO₂ fire extinguisher adjacent to the charging area.

6) No ignition sources

No person carrying out work in relation to a refrigeration system which involves exposing any pipe work that contains or has contained flammable refrigerant shall use any sources of ignition in such a manner that it may lead to the risk of fire or explosion. All possible ignition sources, including cigarette smoking, should be kept sufficiently far away from the site of installation, repairing, removing and disposal, during which flammable refrigerant can possibly be released to the surrounding space. Prior to work taking place, the area around the equipment is to be surveyed to make sure that there are no flammable hazards or ignition risks. NO SMOKING signs shall be displayed.

7) Ventilated area

Ensure that the area is in the open or that it is adequately ventilated before breaking into the system or conducting any hot work. A degree of ventilation shall continue during the period that the work is carried out. The ventilation should safely disperse any released refrigerant and preferably expel it externally into the atmosphere.

8) Checks to the refrigeration equipment

Where electrical components are being changed, they shall be fit for the purpose and to the correct specification. At all times the manufacturer's maintenance and service guidelines shall be followed. If in doubt consult the manufacturer's technical department for assistance. The following checks shall be applied to installations using flammable refrigerants:

- The charge size is in accordance with the room size within which the refrigerant containing parts are installed;
- The ventilation machinery and outlets are operating adequately and are not obstructed;
- If an indirect refrigerating circuit is being used, the secondary circuits shall be checked for the presence of refrigerant; marking to the equipment continues to be visible and legible.
- Marking and signs that are illegible shall be corrected;
- Refrigeration pipe or components are installed in a position where they are unlikely to be exposed to any substance which may corrode refrigerant containing components, unless the components are constructed of materials which are inherently resistant to being corroded or are suitably protected against being so corroded.

9) Checks to electrical devices

Repair and maintenance to electrical components shall include initial safety checks and component inspection procedures. If a fault exists that could compromise safety, then no electrical supply shall be connected to the circuit until it is satisfactorily dealt with. If the fault cannot be corrected immediately but it is necessary to continue operation, and adequate temporary solution shall be used. This shall be reported to the owner of the equipment so all parties are advised.

Initial safety checks shall include:

- That capacitors are discharged: this shall be done in a safe manner to avoid possibility of sparking;
- That there are no live electrical components and wiring are exposed while charging, recovering or purging the system;
- That there is continuity of earth bonding.

10) Repairs to sealed components

a) During repairs to sealed components, all electrical supplies shall be disconnected from the equipment being worked upon prior to any removal of sealed covers, etc. If it is absolutely necessary to have an electrical supply to equipment during servicing, then a permanently operating form of leak detection shall be located at the most critical point to warn of a potentially hazardous situation.

b) Particular attention shall be paid to the following to ensure that by working on electrical components, the casing is not altered in such a way that the level of protection is affected. This shall include damage to cables, excessive number of connections, terminals not made to original specification, damage to seals, incorrect fitting of glands, etc.

- Ensure that apparatus is mounted securely.
- Ensure that seals or sealing materials have not degraded such that they no longer serve the purpose of preventing the ingress of flammable atmospheres. Replacement parts shall be in accordance with the manufacturer's specifications.

NOTE

The use of silicon sealant may inhibit the effectiveness of some types of leak detection equipment. Intrinsically safe components do not have to be isolated prior to working on them.

11) Repair to intrinsically safe components

Do not apply any permanent inductive or capacitance loads to the circuit without ensuring that this will not exceed the permissible voltage and current permitted for the equipment in use. Intrinsically safe components are the only types that can be worked on while live in the presence of a flammable atmosphere. The test apparatus shall be at the correct rating. Replace components only with parts specified by the manufacturer. Other parts may result in the ignition of refrigerant in the atmosphere from a leak.

12) Cabling

Check that cabling will not be subject to wear, corrosion, excessive pressure, vibration, sharp edges or any other adverse environmental effects. The check shall also take into account the effects of aging or continual vibration from sources such as compressors or fans.

13) Detection of flammable refrigerants

Under no circumstances shall potential sources of ignition be used in the searching for or detection of refrigerant leaks. A halide torch (or any other detector using a naked flame) shall not be used.

14) Leak detection methods

The following leak detection methods are deemed acceptable for systems containing flammable refrigerants. Electronic leak detectors shall be used to detect flammable refrigerants, but the sensitivity may not be adequate, or may need re-calibration. (Detection equipment shall be calibrated in a refrigerant-free area.) Ensure that the detector is not a potential source of ignition and is suitable for the refrigerant. Leak detection equipment shall be set at a percentage of the LFL of the refrigerant and shall be calibrated to the refrigerant employed and the appropriate percentage of gas (25% maximum) is confirmed. Leak detection fluids are suitable for use with most refrigerants but the use of detergents containing chlorine shall be avoided as the chlorine may react with the refrigerant and corrode the copper pipe-work. If a leak is suspected, all naked flames shall be removed or extinguished. If a leakage of refrigerant is found which requires brazing, all of the refrigerant shall be recovered from the system, or isolated (by means of shut off valves) in a part of the system remote from the leak. Oxygen free nitrogen (OFN) shall then be purged through the system both before and during the brazing process.

15) Removal and evacuation

When breaking into the refrigerant circuit to make repairs or for any other purpose conventional procedures shall be used. However, it is important that best practice is followed since flammability is a consideration. The following procedure shall be adhered to:

- Remove refrigerant;
- Purge the circuit with inert gas;
- Evacuate;
- Purge again with inert gas;
- Open the circuit by cutting or brazing.

The refrigerant charge shall be recovered into the correct recovery cylinders. The system shall be flushed with OFN to render the unit safe. This process may need to be repeated several times.

Compressed air or oxygen shall not be used for this task.

Flushing shall be achieved by breaking the vacuum in the system with OFN and continuing to fill until the working pressure is achieved, then venting to atmosphere, and finally pulling down to a vacuum. This process shall be repeated until no refrigerant is within the system.

When the final OFN charge is used, the system shall be vented down to atmospheric pressure to enable work to take place. This operation is absolutely vital if brazing operations on the pipe-work are to take place.

Ensure that the outlet for the vacuum pump is not closed to any ignition sources and there is ventilation available.

16) Charging procedures

In addition to conventional charging procedures, the following requirements shall be followed:

- Ensure that contamination of different refrigerants does not occur when using charging equipment. Hoses or lines shall be as short as possible to minimize the amount of refrigerant contained in them.
- Cylinders shall be kept upright.
- Ensure that the refrigeration system is earthed prior to charging the system with refrigerant.
- Label the system when charging is complete (if not already).
- Extreme care shall be taken not to overfill the refrigeration system.
- Prior to recharging the system it shall be pressure tested with OFN. The system shall be leak tested on completion of charging but prior to commissioning. A follow up leak test shall be carried out prior to leaving the site.

17) Decommissioning

Before carrying out this procedure, it is essential that the technician is completely familiar with the equipment and all its detail. It is recommended good practice that all refrigerants are recovered safely. Prior to the task being carried out, an oil and refrigerant sample shall be taken.

In case analysis is required prior to re-use of reclaimed refrigerant. It is essential that electrical power is available before the task is commenced.

a) Become familiar with the equipment and its operation.

b) Isolate system electrically

c) Before attempting the procedure ensure that:

- Mechanical handling equipment is available, if required, for handling refrigerant cylinders;
- All personal protective equipment is available and being used correctly;
- The recovery process is supervised at all times by a competent person;
- Recovery equipment and cylinders conform to the appropriate standards.

d) Pump down refrigerant system, if possible.

e) If a vacuum is not possible, make a manifold so that refrigerant can be removed from various parts of the system.

f) Make sure that cylinder is situated on the scales before recovery takes place.

g) Start the recovery machine and operate in accordance with manufacturer's instructions.

h) Do not overfill cylinders. (No more than 80% volume liquid charge).

i) Do not exceed the maximum working pressure of the cylinder, even temporarily.

j) When the cylinders have been filled correctly and the process completed, make sure that the cylinders and the equipment are removed from site promptly and all isolation valves on the equipment are closed off.

k) Recovered refrigerant shall not be charged into another refrigeration system unless it has been cleaned and checked.

18) Labelling

Equipment shall be labelled stating that it has been de-commissioned and emptied of refrigerant. The label shall be dated and signed. Ensure that there are labels on the equipment stating the equipment contains flammable refrigerant.

19) Recovery

When removing refrigerant from a system, either for service or decommissioning, it is recommended good practice that all refrigerants are removed safely.

When transferring refrigerant into cylinders, ensure that only appropriate refrigerant recovery cylinders are employed. Ensure that the correct numbers of cylinders for holding the total system charge are available. All cylinders to be used are designated for the recovered refrigerant and labelled for that refrigerant (i.e special cylinders for the recovery of refrigerant). Cylinders shall be complete with pressure relief valve and associated shut-off valves in good working order.

Empty recovery cylinders are evacuated and, if possible, cooled before recovery occurs.

The recovery equipment shall be in good working order with a set of instructions concerning the equipment that is at hand and shall be suitable for the recovery of flammable refrigerants. In addition, a set of calibrated weighing scales shall be available and in good working order.

Hoses shall be complete with leak-free disconnect couplings and in good condition. Before using the recovery machine, check that it is in satisfactory working order, has been properly maintained and that any associated electrical components are sealed to prevent ignition in the event of a refrigerant release. Consult manufacturer if in doubt.

The recovered refrigerant shall be returned to the refrigerant supplier in the correct recovery cylinder, and the relevant Waste Transfer Note arranged. Do not mix refrigerants in recovery units and especially not in cylinders.

If compressors or compressor oils are to be removed, ensure that they have been evacuated to an acceptable level to make certain that flammable refrigerant does not remain within the lubricant. The evacuation process shall be carried out prior to retraining the compressor to the suppliers. Only electric heating to the compressor body shall be employed to accelerate this process. When oil is drained from a system, it shall be carried out safely.

20) Transportation, marking and storage for units

Transport of equipment containing flammable refrigerants Compliance with the transport regulations

Marking of equipment using signs Compliance with local regulations

Disposal of equipment using flammable refrigerants Compliance with national regulations

Storage of equipment/appliances

The storage of equipment should be in accordance with the manufacturer's instructions.

Storage of packed (unsold) equipment

Storage package protection should be constructed such that mechanical damage to the equipment inside the package will not cause a leak of the refrigerant charge.

The maximum number of pieces of equipment permitted to be stored together will be determined by local regulations.

ANNEX A: Refrigerant cycle

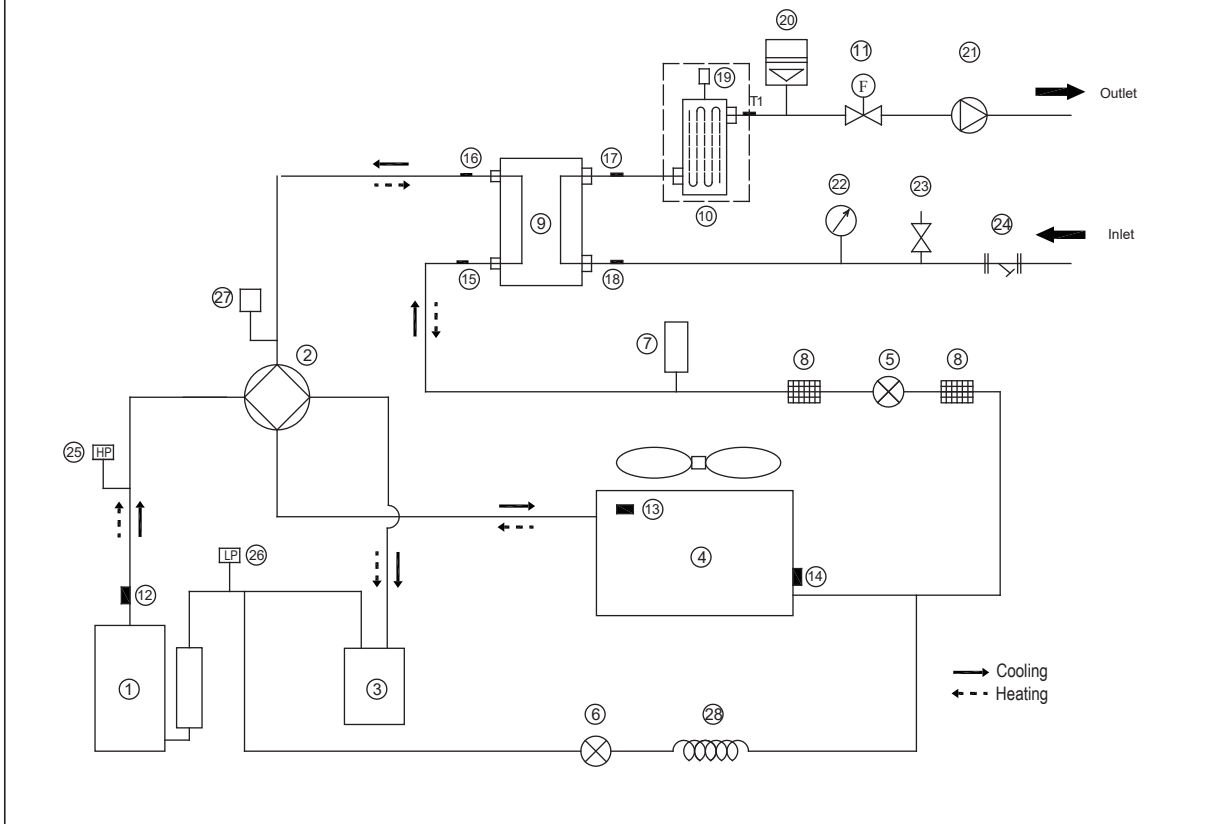

Item	Description	Item	Description
1	Compressor	15	Refrigerant inlet (liquid pipe) temp. sensor
2	4-Way Valve	16	Refrigerant outlet (gas pipe) temp. sensor
3	Gas-liquid separator	17	Water outlet temp. sensor
4	Air side heat exchanger	18	Water Inlet temp. sensor
5	Electronic expansion Valve	19	Air purge valve
6	Single-way electromagnetic valve	20	Expansion vessel
7	Liquid Tank	21	Circulating pump
8	Strainer	22	Manometer
9	Water Side Heat Exchanger (Plate Heat Exchange)	23	Safety valve
10	Backup heater (optional)	24	Y-shape filter
11	Flow switch	25	High Pressure Switch
12	Discharge gas sensor	26	Low Pressure Switch
13	Outdoor temperature sensor	27	Pressure valve
14	Evaporation sensor in heating (Condenser sensor in cooling)	28	Capillary

ANNEX B: Electrically controlled wiring diagram 1-phase 5/7/9kW

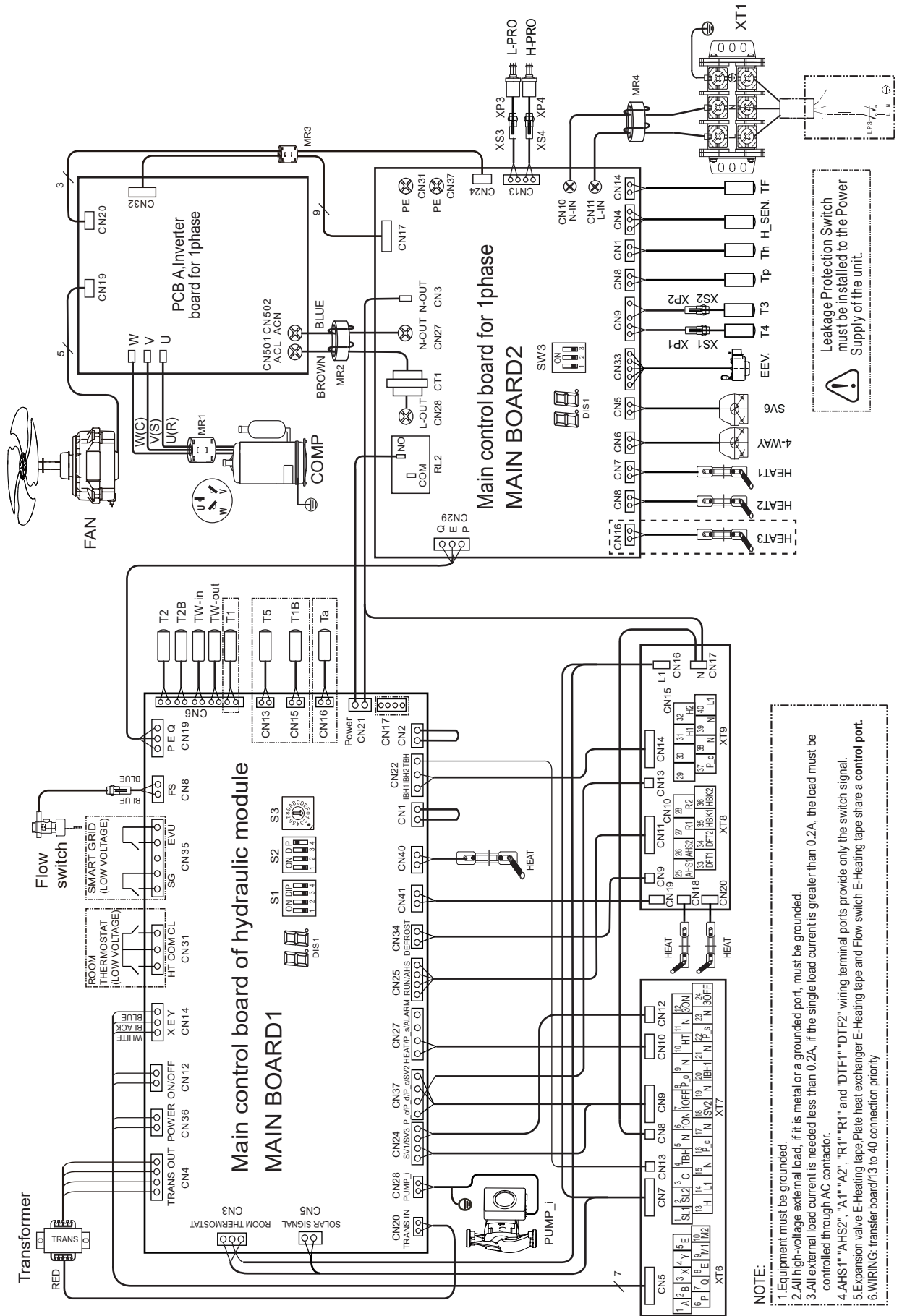

Leakage Protection Switch must be installed to the Power Supply of the unit.

NOTE:

1. Equipment must be grounded.
2. All high-voltage external load, if it is metal or a grounded port, must be grounded.
3. All external load current is needed less than 0.2A, if the single load current is greater than 0.2A, the load must be controlled through AC contactor.
4. AHS1: "AHS2", "A1", "A2", "R1" and "DTF1" wiring terminal ports provide only the switch signal.
5. Expansion valve E-Heating tape-Plate heat exchanger E-Heating tape and Flow switch E-Heating tape share a control port.
6. WIRING: transfer board/13 to 40 connection priority

Annex B: Electrically controlled wiring diagram 1-phase 12/14/16kW

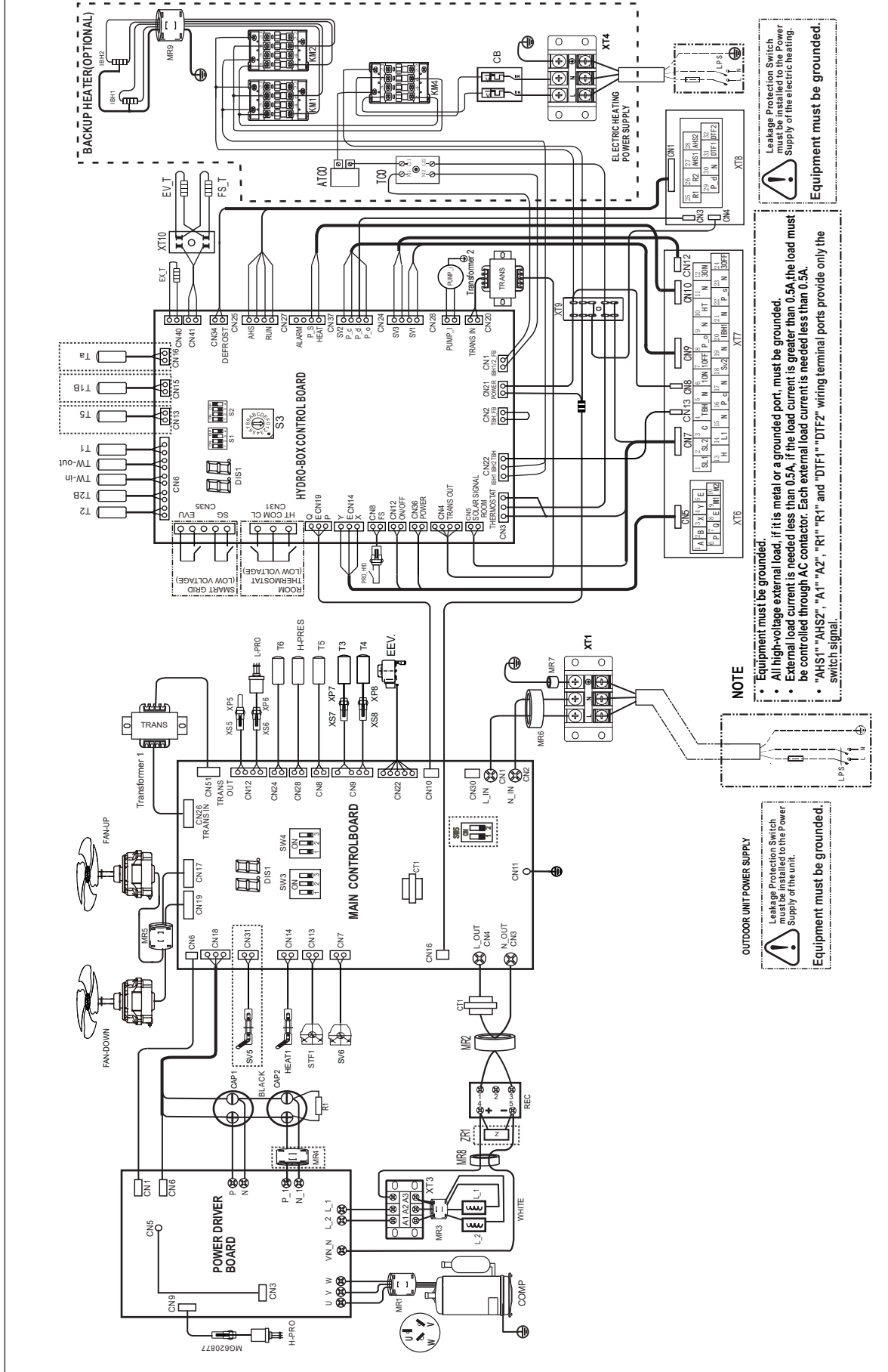

Annex B: Electrically controlled wiring diagram 3-phase 12/14/16kW

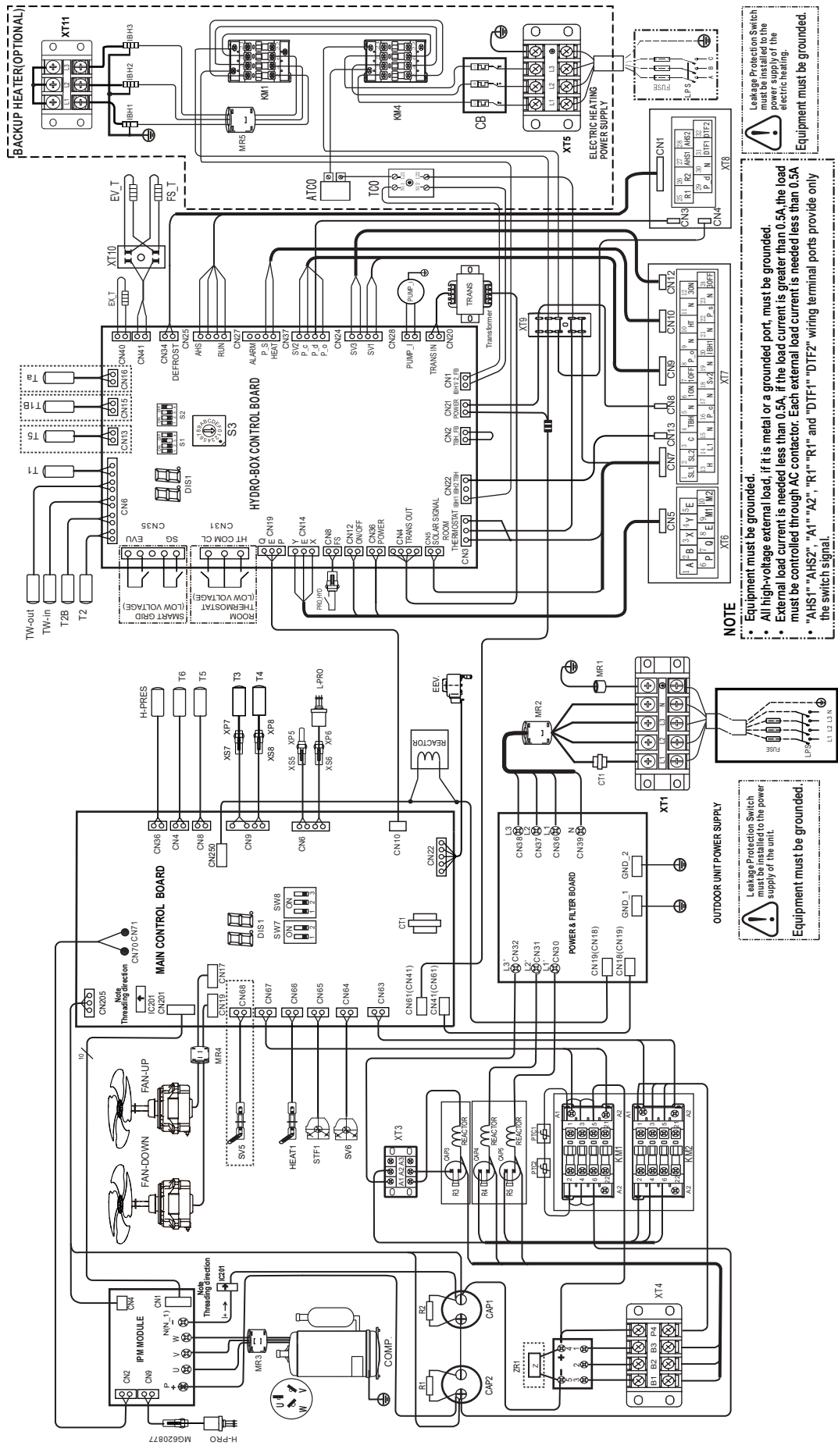

NOTE

A series of horizontal dotted lines for writing notes.

NOTE

A series of horizontal dotted lines for writing notes.

16125300001699 V5.0